

# ALLWIN 奥文 PRODUCT CATALOGUE



授权经销:  
AUTHORIZED DEALER:



[www.allwin-motor.com](http://www.allwin-motor.com)



## ALLWIN 奥文 2020

文登奥文电机有限公司 (原文登市电机厂)  
WENDENG ALLWIN MOTORS MANUFACTURING CO.,LTD.  
(Former: Wendeng Electrical Machinery Factory)

地址: 中国·山东省威海市文登经济开发区昆甯北路196号  
Add: Industrial Motor Factory Located @ No. 196 Kunyi North Road,  
Wendeng Economic Development Zone, Weihai, Shandong,  
China 264400

四产路分公司: 山东省威海市文登经济开发区四产路15号  
Power Tool Branch Office Add: 2 Power Tool Factorys Located @ No. 15  
Sichan Road, Wendeng Economic Development Zone, Weihai, Shandong,  
China 264400

Tel:+86-631-846 0181  
Fax:+86-631-845 1624  
[marketing@allwin-motor.com](mailto:marketing@allwin-motor.com)





## Wendeng Allwin Motors Manufacturing Co., Ltd.

文登奥文电机有限公司

### ALLWIN FOUNDED IN 1955....

Motor production since 1978

Power tools business start from 1989

### CAPACITY

Our 45 high efficiency LEAN manufacturing lines located in our 3 factories, they can produce 4 categories & 500+ products with rapid line shifting in very short time. We ship out over 2100 container of high quality products to China & Int'l markets serving more than 70 global famous motor and power tools brands & hardware/home center store chains.

### PROFESSIONAL

30+ years OEM business practice since 1989 serving 70+ top brands.



Company Headquarter & Industrial Motor Factory @ No. 196 Kunyu Road



Power Tool & Gardening Machinery Factory @ No. 15 & 18 Sichan Road, Wendeng Economic Development Zone

昆崙路196号的公司总部和工业电机分厂

位于文登开发区四产路15和18号的电动工具和园林机械分厂

# CONTENTS

## 目录

**BENCH GRINDER**  
砂轮机



Page: 1-15

**SHARPENER**  
磨刀机



Page: 16-18

**BENCH GRINDER SANDER**  
砂轮砂带机



Page: 19-21

**BUFFING MACHINE**  
抛光机



Page: 22-23

**SANDING MACHINE**  
砂光机



Page: 24-30

**FLOOR CARE**  
地板修理



Page: 31

**BENCH GRINDER STAND**  
砂轮机支架



Page: 32

**DRILL PRESS**  
台钻



Page: 33-39

**SCROLL SAW**  
台式曲线锯



Page: 40-46

**BAND SAW**  
带锯



Page: 47-50

**TABLE SAW**  
台锯



Page: 51-54

**PLANNER THICKNESSER**  
平压刨



Page: 55

**Vertical Spindle Moulder**  
铣床



Page: 56

**DUST COLLECTOR**  
集尘器



Page: 57-62

**FUME/SMOKE EXHAUSTER**  
排烟机

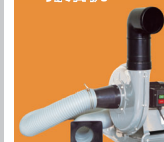

Page: 63

**GARDEN SHREDDER**  
花园碎枝机



Page: 64

**CONCRETE MIXER**  
水泥搅拌机



Page: 65

**ACCESSORY**  
附件



Page: 66-68

# TDS LINE BENCH GRINDER TDS 系列砂轮机

Bench Grinder  $\phi$  150mm/6 inch  
**TDS-150EBL2** 

**400 W**



**Adjustable eyeshield and spark deflector**  
可调节的护目镜和火花挡板

**3 Bulbs LED light with independent switch**  
带独立开关的3头LED灯

**Optional cast iron base**  
可选铸铁底座

**Optional cast AL base**  
可选铝压铸底座

**Steel base**  
钢板底座

Bench Grinder  $\phi$  150mm/6 inch  
**TDS-150EBL3** 

**400 W**

- **LED Light powered by battery**  
Angle adjustable LED light illuminates the work space, promoting accurate sharpening.
- **Protective Eye Guards**  
Eye guards provide vital protection from spark and debris for safe operation.
- 电池供电LED灯
- 护镜阻止火花和碎屑



## TDS LINE BENCH GRINDER / TDS系列砂轮机特点

**TECHNICAL FEATURES AND STANDARD FITTINGS**

**CLASSIC LINE OF BENCH GRINDER**

- Reliable and silent induction motors with ball bearing
- Accept both wire wheel and grinding wheel
- Equipped with adjustable work rest and safety glass
- Targeted for hobby to professionals
- Three phase available for 8 and 10 inch
- Lamp available for all line

**经典砂轮机系列**

- 可靠，安静的感应马达
- 可安装标准砂轮片以及钢丝轮
- 标配活动托架，护目镜
- 可满足从爱好者到专业人士的不同需要
- 200以及250毫米砂轮机可选三相电机
- 所有TDS系列砂轮机可选配灯

# TDS LINE BENCH GRINDER TDS 系列砂轮机

Bench Grinder  $\phi$  200mm/8inch  
**TDS-200EBL2** 

Bench Grinder  $\phi$  200mm/8inch  
**TDS-200EBL3** 

**500 W**



**3 Bulbs LED light with independent switch**  
带独立开关的3头LED灯

**Stable work rest, tool-less adjustable**  
可靠的托架，无需工具即可调节

**Optional cast iron base**  
可选铸铁底座

**Optional cast AL base**  
可选铝压铸底座

**40 mm wide WA grinding wheel for low temperaturesharpening**  
40mm宽白刚玉砂轮片对工件进行低温磨削

- Powerful 500W motor delivers smooth, accurate results
- Eye shields protect you from flying debris without obstructing your view
- Inbuilt LED worklights over wheels keep work piece illuminate
- Cast-AL base with pre-drilled holes for quick and easy mounting to a benchtop
- Adjustable tool rests extend the life of the grinding wheels
- Rubber feet for increasing stability
- 配套强大的500瓦电机，带来平顺和精确的打磨效果
- 护目镜能够保护你远离火花，不会影响视线
- 内置的LED灯，可以照亮工件
- 带有2个固定孔的铝压铸底座，可以方便的固定在台面上
- 托架可以跟随砂轮片调节，延长砂轮片的使用寿命
- 橡胶底脚增加了机器的稳定性

## Technical Data/技术参数

Model/型号	WATT		$\phi$ mm		Motor speed/马达转速 50Hz 60Hz	Carton size/包装尺寸 MM	N.W./G.W. 净重/毛重 KG	Container load/装柜数		
	Watts (S1)	Watts (S2 10min)	Wheel size/砂轮尺寸 MM	Wheel grit/砂轮粒度 Inch				20 GP	40 GP	40 HP
TDS-150EBL2	250	400	150*20*12.7	6*3/4*1/2	2980 3580	395*255*245	8.0 / 9.2	1224	2403	2690
TDS-150EBL3	250	400	150*20*12.7	6*3/4*1/2	2980 3580	395*255*245	8.0 / 9.2	1224	2403	2690
TDS-200EBL2	250	500	200*20*15.88	8*3/4*5/8	2980 3580	425*320*310	11.5 / 13.0	632	1302	1450
TDS-200EBL3	250	500	200*20*15.88	8*3/4*5/8	2980 3580	440*320*310	13.5 / 15.0	725	1442	1662

# TDS LINE BENCH GRINDER



# TDS 系列砂轮机

# TDS LINE BENCH GRINDER

# TDS 系列砂轮机

Bench Grinder  $\phi$  125mm/5 inch  
**TDS-125B** 

  
**180 W**

Bench Grinder  $\phi$  150mm/6 inch  
**TDS-150EB**  

  
**250 W**

- Adjustable work rest and spark deflector
- Optional magnifier shield for precision grinding
- 可调节的托架以及火花挡板
- 选配的放大镜可以更精确的观察工件



**TDS-150EC**  
Cast AL base  
铝压铸底座

**Steel base**  
钢板底座

Bench Grinder  $\phi$  150mm/6 inch  
**TDS-150EBL** 

  
**250 W**



- 3 Times Magnifier shield
- Industrial lamp with E27 Bulb Holder
- Patent Rigid steel base, stable and light weight
- 3倍放大护目镜
- 工业款灯罩, 使用E 27灯口
- 专利牢固, 轻便的钢板底座

Bench Grinder  $\phi$  150mm/6 inch  
**TDS-150CL**  
Bench Grinder  $\phi$  200mm/8 inch  
**TDS-200CL** 

  
**370 W**  
  
**550 W**



- Optional quick wheel guard release
- Coolant tray
- Magnifier shield
- Cast Aluminum base
- Industrial light
- 可选快速拆卸护罩
- 冷却水槽
- 放大护目镜
- 铝压铸底座
- 工业款灯罩

Bench Grinder  $\phi$  175mm/7 inch  
**TDS-175C** 

  
**375 W**





**Coolant tray**  
冷却水槽

- Quick wheel guard release
- Cast AL base
- Tool less adjustable eyeshield and work rest
- 快速拆卸护罩
- 铅压铸底座
- 不需要工具的附件调节

Bench Grinder  $\phi$  150mm/6 inch  
**TDS-150**

Bench Grinder  $\phi$  200mm/8 inch  
**TDS-200EA** 

Bench Grinder  $\phi$  200mm/8 inch  
**TDS-200EB** 

  
**370 W**  
  
**550 W**



- Cast iron base
- Adjustable work rest and spark deflector
- 铸铁底座
- 可调节的托架以及火花挡板

Bench Grinder  $\phi$  200mm/8 inch  
**TDS-200H**

Bench Grinder  $\phi$  250mm/10 inch  
**TDS-250E**

  
**750 W**  
  
**1~**   
**3~**

- Cast iron motor housing
- Cast iron base
- 750W motor available
- 铸铁马达壳
- 铸铁底座
- 可选最大750瓦特马达



## Technical Data/技术参数

Model/型号	WATT		$\phi$ mm		RPM		a x b x h mm		NW./G.W. 净重/毛重	Container load/装箱数		
	Power/功率		Wheel size/砂轮尺寸		Motor speed/马达转速		Carton size/包装尺寸			Container load/装箱数		
	Watts (S1)	Watts (S2 30min)	MM	Inch	50Hz	60Hz	MM	KG		20 GP	40 GP	40 HP
TDS-125B	120	180	125*16*12.7	5*5/8*1/2	36# / 60#	2980	3580	345*240*245	5.5 / 6.5	1485	2889	3320
TDS-150EB	180	250	150*20*12.7	6*3/4*1/2	36# / 60#	2980	3580	345*240*245	6.5 / 7.6	1485	2889	3320
TDS-150EBL	180	250	150*20*12.7	6*3/4*1/2	36# / 60#	2980	3580	460*240*240	7.3 / 8.3	1098	2205	2739
TDS-150CL	250	370	150*20*12.7	6*3/4*1/2	36# / 60#	2980	3580	510*295*255	8.0 / 9.3	801	1602	1830
TDS-200CL	370	550	200*25*15.88	8*1*5/8	36# / 60#	2980	3580	530*325*305	14.0 / 15.3	539	1085	1240

## Technical Data/技术参数

Model/型号	WATT		$\phi$ mm		RPM		a x b x h mm		NW./G.W. 净重/毛重	Container load/装箱数		
	Power/功率		Wheel size/砂轮尺寸		Motor speed/马达转速		Carton size/包装尺寸			Container load/装箱数		
	Watts (S1)	Watts (S2 30min)	MM	Inch	50Hz	60Hz	MM	KG		20 GP	40 GP	40 HP
TDS-150	250	370	150*25*12.7	6*1*1/2	36# / 60#	2980	3580	427*310*280	8.3 / 9.6	824	1616	1854
TDS-175C	250	375	175*25*15.88	7*1*5/8	36# / 60#	2980	3580	430*330*310	12.2 / 13.5	672	1320	1520
TDS-200EA	250	370	200*25*15.88	8*1*5/8	36# / 60#	2980	3580	420*375*290	14.5 / 16.0	688	1368	1566
TDS-200EB	370	550	200*25*15.88	8*1*5/8	36# / 60#	2980	3580	420*375*290	15.0 / 16.8	688	1368	1566
TDS-200H	550	750	200*25*15.88	8*1*5/8	36# / 60#	2980	3580	450*345*330	12.0 / 13.5	602	1204	1376
TDS-250E	550	750	250*25*20	10*1*3/4	36# / 60#	2980	1790	450*345*330	21.0 / 23.0	602	1204	1376

# TDS LINE BENCH GRINDER

# TDS 系列砂轮机

Bench Grinder  $\phi$  250mm/10inch  
TDS-250



750 W



Optional work stand  
可选配支架



## 10" HEAVY DUTY BENCH GRINDER /10寸重型砂轮机

- Heavy duty motor
- Cast iron motor housing
- Cast iron base
- Forward wheel guard minimize the fly of sparks

- 重型马达设计
- 铸铁马达壳
- 铸铁底座
- 前突的护罩使飞溅的火花减少到最小

Bench Grinder  $\phi$  250mm/10inch  
TDS-250H

900 W

1~ 3~



Cast Aluminum work rest  
铝压铸工作台

Safety switch with key  
带钥匙的安全开关

- Heavy duty motor
- Cast iron motor housing
- Cast iron base

- 重型马达设计
- 铸铁马达壳
- 铸铁底座

### Technical Data/技术参数

Model/型号	WATT		$\phi$ mm		RPM		a x b x h mm	kg	Container load/ 装箱数			
	Power/功率		Wheel size/砂轮尺寸		Motor speed/马达转速				N.W./G.W. 净重/毛重	Container load/ 装箱数		
	Watts (S1)	Watts (S2 30min)	MM	Inch	50Hz	60Hz				20 GP	40 GP	40 HP
TDS-250	550	750	250*25*20	10"1/3/4	36# / 60#	2980	1790	520*395*365	29.5 / 31.5	378	750	875
TDS-250H	750	900	250*25*20	10"1/3/4	36# / 60#	2980	1790	520*395*365	30.0 / 32.0	378	750	875

# HBG LINE BENCH GRINDER

# H B G 系列砂轮机

Bench Grinder  $\phi$  150mm/6 inch  
HBG620A



250 W

Bench Grinder  $\phi$  150mm/6 inch  
HBG625L



370 W

## HBG LINE BENCH GRINDER HBG系列砂轮机特点

- Streamlined double shield induction motor design  
流线型双层壳感应马达
- Accept both wire wheel and grinding wheel  
可安装标准砂轮片以及钢丝轮
- Equipped with adjustable work rest and safety glass  
标配活动托架, 护目镜
- Targeted for hobby to professionals  
可满足从爱好者到专业人士的不同需要
- Three phase available for 8 and 10 inch  
200 以及250毫米砂轮机可选三相电机



10w Flexible working light  
可灵活转动的10瓦白炽灯  
Optional LED light(1 Watt)  
可选1瓦二极管灯

Bench Grinder with brush wheel  $\phi$  150mm/6 inch  
HBG620B



250 W



Wheel Dresser  
砂轮修整器

For cleaning and reshaping the grinding wheel between uses. Stored on clip on the top of grinder when not in use.  
用于处理砂轮磨削面, 不使用时存放在机器上顶

- Flexible working light
- 3 Times Magnifier Shield
- Quick wheel guard release
- Includes water cooling tray and wheel dresser
- Streamlined Double shield motor Low surface temperature
- 可灵活转动的工作灯
- 3倍放大护目镜
- 护罩快速拆卸功能
- 内置冷却水槽和砂轮修整器
- 低表面温度的流线型双层马达壳设计



Rust removal, cleaning of metal and non ferrous metal  
钢丝轮主要用于除锈, 清理有色金属等

### Technical Data/技术参数

Model/型号	WATT		$\phi$ mm		RPM		a x b x h mm	kg	Container load/ 装箱数			
	Power/功率		Wheel size/砂轮尺寸		Motor speed/马达转速				N.W./G.W. 净重/毛重	Container load/ 装箱数		
	Watts (S1)	Watts (S2 30min)	MM	Inch	50Hz	60Hz				20 GP	40 GP	40 HP
HBG620A	150	250	150*20*12.7	6"3/4"1/2	36# / 60#	2980	3580	425*255*290	9.3 / 10.0	984	1984	2232
HBG625L	250	370	150*25*12.7	6"1"1/2	36# / 60#	2980	3580	440*255*290	10.0 / 11.0	960	1920	2196
HBG620B	150	250	150*20*12.7	6"3/4"1/2	36# (left) Brush wheel	2980	3580	425*255*290	9.1 / 9.8	984	1984	2232

# HBG LINE BENCH GRINDER

# HBG 系列砂轮机

Bench Grinder $\phi$ 200mm/8 inch <b>HBG818L</b>			<b>370 W</b>
Bench Grinder $\phi$ 200mm/8 inch <b>HBG825L</b>			<b>550 W</b>
Bench Grinder $\phi$ 250mm/10 inch <b>HBG1025L</b>			<b>750 W</b>

- Cast aluminum housing
- Flexible working light
- 3 Times Magnifier Shield
- Quick wheel guard release
- Includes water cooling tray and hand held wheel dresser
- 铝压铸机身
- 可灵活转动的工作灯
- 3倍放大护目镜
- 护罩快速拆卸功能
- 内置冷却水槽和手持砂轮修整器



Bench Grinder $\phi$ 150mm/6 inch <b>HBG620HA</b>			<b>250 W</b>
Bench Grinder $\phi$ 200mm/8 inch <b>HBG825HL</b>			<b>550 W</b>

- Cast Aluminum Base
- Flexible working light
- 3 Times Magnifier Shield
- Angle adjustable work rest
- Includes water cooling tray and hand held wheel dresser
- Include 40mm width WA grinding wheel
- 铝压铸底座
- 可灵活转动的工作灯
- 3倍放大护目镜
- 角度可调节的工作台
- 内置冷却水槽和手持砂轮修整器
- 带一片40mm厚度的白刚玉砂轮片



40mm width WA grinding wheel for low temperature sharpening  
40mm 宽白刚玉砂轮片对工件进行低温磨削

# TLG LINE BENCH GRINDER

# TLG 系列砂轮机

Bench Grinder $\phi$ 150mm/6 inch <b>TLG-150AL</b>	
---	--

**250 W**

**3 Times Magnifier**  
3倍放大护镜



**In-Built Coolant Tray**  
内置冷却水槽

**Angle adjustable work rest**  
角度可调的托架

## TLG LINE BENCH GRINDER / TLG系列砂轮机特点

### TECHNICAL FEATURES AND STANDARD FITTINGS

- Auto lighted twin lamp
- Accept both wire wheel and grinding wheel
- Equipped with AI adjustable work rest and eye shield
- Targeted for hobby to professionals
- 自动开启的双灯
- 可安装标准砂轮片以及钢丝轮
- 标配角度可调的铝托架，护目镜
- 可满足从爱好者到专业人士的不同需要

### Technical Data/技术参数

Model/型号	Power/功率		Wheel size/砂轮尺寸		Wheel grit/砂轮粒度	Motor speed/马达转速		Carton size/包装尺寸	N.W./G.W. 净重/毛重	Container load/装柜数		
	Watts (S1)	Watts (S2 30min)	MM	Inch		50Hz	60Hz			20 GP	40 GP	40 HP
	MM	Inch	Left / Rihgt	MM	KG	20 GP	40 GP	40 HP				
HBG818L	250	370	200*20*15.88	8*3/4*5/8	36# / 60#	2980	3580	465*345*325	14.5 / 16.0	595	1127	1360
HBG825L	370	550	200*25*15.88	8*1*5/8	36# / 60#	2980	3580	480*345*325	15.0 / 16.5	560	1120	1200
HBG620HA	180	250	150*20*12.7	6*3/4*1/2	36#	2980	3580	425*235*290	9.8 / 10.5	984	1984	2232
HBG825HL	370	550	200*25*15.88	8*1*5/8	60#	2980	3580	480*335*325	18.0 / 19.2	535	1070	1150
			200*40*15.88	8*1-1/2*5/8	100#							
HBG1025L	550	750	250*25*20	10*1*3/4	36# / 60#	2980	1790	525*385*350	25.5 / 27.0	448	896	1088

### Technical Data/技术参数

Model/型号	Power/功率		Wheel size/砂轮尺寸		Wheel grit/砂轮粒度	Motor speed/马达转速		Carton size/包装尺寸	N.W./G.W. 净重/毛重	Container load/装柜数		
	Watts (S1)	Watts (S2 30min)	MM	Inch		50Hz	60Hz			20 GP	40 GP	40 HP
	MM	Inch	Left / Rihgt	MM	KG	20 GP	40 GP	40 HP				
TLG-150AL	180	250	150*20*12.7	6*3/4*1/2	36# / 60#	2980	3580	370*335*260	9.8 / 11.0	918	1890	2100
TLG-200L2	250	370	200*25*15.88	8*1*5/8	36# / 60#	2980	3580	420*390*285	16.0 / 17.3	672	1200	1512

# TLG LINE BENCH GRINDER

# TLG系列砂轮机

Bench Grinder  $\phi$  200mm/8 inch  
TLG-200L4

550 W

Auto In-built two light  
自动开启的内置双灯

Cast aluminum angle adjustable work rest  
铝压铸工作台，角度可调



3 Times Magnifier shield  
3倍放大护目镜

Cast iron base  
铸铁底座



**PATENTED: Auto In-built Twin Light**  
专利点：自动开启的内置双灯



**Magnifier shield**  
放大护目镜

- Coolant tray
- Heavy cast iron base
- Cast aluminum angle adjustable work rest
- Heavy cast iron base with rubber feet and 4 mounting holes
- 冷却水槽
- 重型铸铁底座
- 铝压铸工作台，角度可调
- 重型的铸铁底座带有4个安装孔和橡胶脚

## Technical Data/技术参数

Model/型号	WATT		$\phi$ mm		RPM		a x b x h mm	NW /GW 净重/毛重	Container load/ 装柜数			
	Power/功率		Wheel size/砂轮尺寸		Motor speed/马达转速				Container load/ 装柜数			
	Watts (S1)	Watts (S2 30min)	MM	Inch	50Hz	60Hz			20 GP	40 GP	40 HP	
TLG-200L3	250	370	200*25*15.88	8"1"5/8"	36# / 60#	2980	3580	415*370*280	15.0 / 16.5	704	1368	1566
TLG-200L4	370	550	200*25*15.88	8"1"5/8"	36# / 60#	2980	3580	415*370*280	15.3 / 16.8	704	1368	1566

# RBG LINE BENCH GRINDER

# RBG 系列砂轮机

Bench Grinder  $\phi$  150mm/6 inch  
RBG618A

250 W

Bench Grinder  $\phi$  150mm/6 inch  
RBG625A

370 W

Bench Grinder  $\phi$  200mm/8 inch  
RBG818A

370 W

Bench Grinder  $\phi$  200mm/8 inch  
RBG825A

550 W



Auto In-built twin light  
自动开启的内置双灯

Streamlined double shield motor Low surface temperature  
低表面温度的流线型双层马达壳设计



## RBG LINE BENCH GRINDER / RBG系列砂轮机特点

### TECHNICAL FEATURES AND STANDARD FITTINGS

- Coolant tray
- Auto lighted twin lamp
- Accept both wire wheel and grinding wheel
- Equipped with angle adjustable magnifying glass
- Targeted for hobby to professionals
- 冷却水槽
- 自动开启的双灯
- 可安装标准砂轮片以及钢丝轮
- 标配带角度调节的放大镜
- 可满足从爱好者到专业人士的不同需要

## Technical Data/技术参数

Model/型号	WATT		$\phi$ mm		RPM		a x b x h mm	NW /GW 净重/毛重	Container load/ 装柜数			
	Power/功率		Wheel size/砂轮尺寸		Motor speed/马达转速				Container load/ 装柜数			
	Watts (S1)	Watts (S2 30min)	MM	Inch	Left / Right	50Hz			60Hz	20 GP	40 GP	40 HP
RBG618A	180	250	150*20*12.7	6"3/4"1/2"	36# / 60#	2980	3580	400*345*250	9.5 / 10.2	880	1800	1940
RBG625A	250	370	150*20*12.7	6"3/4"1/2"	36# / 60#	2980	3580	400*345*250	10.3 / 11.0	880	1800	1940
RBG818A	250	370	200*20*15.88	8"3/4"5/8"	36# / 60#	2980	3580	435*395*315	15.7 / 16.9	545	1123	1160
RBG825A	370	550	200*25*15.88	8"1"5/8"	36# / 60#	2980	3580	435*395*315	16.3 / 17.5	545	1123	1160

# PBG BENCH GRINDER PBG 砂轮机

Bench Grinder  $\phi$ 150mm/6inch  
PBG-150L2



250W

Handle 提手

Angle adjustable LED light  
角度可调的LED灯

Wholeness motor housing and base, cast aluminium, good looking, low vibration base  
一体的机壳和底座, 铸铝材质, 优质的外观, 低振动底座

WA grinding wheel (wire brush blade disc sharpen optional)  
钢丝轮磨锯片架, 可选

## NEW BENCH GRINDER WITH PORTABLE HANDLE 新款带提手砂轮机



Tool Free Adjustable

可靠的托架, 无需工具即可调节



Adjustable Eyeshields & Spark Deflectors

可调节的火花挡板和护目镜



Optional LED Lights

可选LED灯



Optional Cutter Blade Sharpening Jig

可选磨片抛光刀架

### Technical Data/技术参数

Model/型号	WATT		$\phi$ mm		RPM		a x b x h (mm)		N.W./G.W. 净重/毛重 KG	Container load/装箱数			
	Power/功率		Wheel size/砂轮尺寸		Motor speed/马达转速		MM	Inch		MM	20 GP	40 GP	40 HP
	Watts (S1)	Watts (S2 30min)	MM	Inch	Left / Right	50Hz							
PBG-150L2	180	250	150*20*12.7	6"3/4"1/2	36# / 60#	2980	3580	365*250*280	7.5 / 8.5	1192	2304	2691	

# SPECIAL BENCH GRINDER 特种砂轮机系列

Bench Grinder  $\phi$  200mm/8inch  
TDS-200DS



300 W

Powerful two speed motor  
强劲的双速马达

Cast aluminum work rest  
铝压铸工作台

Switch with two speed position  
双速调节开关

Cast iron base with anti-vibration rubber feet  
带减震橡胶底座的铸铁底座

Main safety switch with key  
主开关

## DUAL SPEED GRINDER 8IN. / 8寸双速砂轮机

### TECHNICAL FEATURES AND STANDARD FITTINGS

#### Two speed sharpen with different grinding wheel

- Angle adjustable work rest
- Tool-less adjustment
- Cast AL tool rests are adjustable for wheel wear and angle grinding
- Powerful two speed induction motor, quick startup, smooth performance and steady speeds at both low or high speed

可使用不同的砂轮进行高速或低速打磨

- 可旋转的托架
- 无需工具即可调节
- 铝压铸工作台角度可调, 用于砂轮打磨
- 强力的双速感应马达, 启动迅速, 运行平稳, 高低速稳定

### Technical Data/技术参数

Model/型号	WATT		$\phi$ mm		RPM		a x b x h (mm)		N.W./G.W. 净重/毛重 KG	Container load/装箱数			
	Power/功率		Wheel size/砂轮尺寸		Motor speed/马达转速		MM	Inch		MM	20 GP	40 GP	40 HP
	Watts (S1)	Watts (S2 30min)	MM	Inch	Left / Right	50Hz							
TDS-200DS	180	300	200*25*15.88	8"1"5/8	80# / 60#	1490/2980	1790/3580	585*365*310	16 / 17.5	434	868	1024	



# SPECIAL BENCH GRINDER

# 特种砂轮机系列

Bench Grinder  $\phi$  200mm/8inch  
TDS-200C4



370 W

## 8" LOW SPEED BENCH GRINDER / 8寸低速砂轮机

- Low speed motor
- High quality WA grinding wheel
- Angle adjustable work rest
- Safety switch with key
- 低速马达
- 高品质的白刚玉砂轮片
- 角度可调节的工作台
- 带安全锁开关

Bench Grinder  $\phi$  200mm/8inch  
TDS-200D4



3 Times magnifier shield  
3倍放大护目镜

700 W

## 8" Heavy Duty Low Speed Bench Grinder / 8寸重型低速砂轮机

- High quality WA grinding wheel
- Cast iron Base with rubber feet
- Adjustable work rest and spark deflector
- 高品质的白刚玉砂轮片
- 铸铁底座带脚
- 可调节的托架及火花挡板

**KEEP IT COOL - Ideal for sharpening operations because it reduces heat build-up**  
防止工件过热-白刚玉砂轮片可以在磨削时降低工件温度, 适合打磨作业

### Technical Data/技术参数

Model/型号	WATT		$\phi$ mm		RPM		a x b x h mm		N.W./G.W. 净重/毛重	Container load/ 装柜数		
	Power/功率		Wheel size/砂轮尺寸		Motor speed/马达转速		Carton size/包装尺寸			Container load/ 装柜数		
	Watts (S1)	Watts (S2 30min)	MM	Inch	50Hz	60Hz	MM	KG		20 GP	40 GP	40 HP
TDS-200C4	250	370	200*25*15.88	8"1/5/8	60# / 120#	1490	1790	480*375*285	15.5 / 17.0	592	1192	1341
TDS-200D4	500	700	200*25*15.88	8"1/5/8	60# / 120#	1490	1790	620*400*370	24.5 / 26.5	312	636	742

# SPECIAL BENCH GRINDER

# 特种砂轮机系列

Bench Grinder  $\phi$  150mm  
TDS-G150V



300 W

Bench Grinder  $\phi$  150mm  
TDS-G150VLDB



300 W

Bench Grinder  $\phi$  200mm  
TDS-G200V



550 W

Bench Grinder  $\phi$  200mm  
TDS-G200VLDB



550 W



Variable speeds  
调速设计

Right side wire wheel  
右侧钢丝轮



Coolant tray  
Tool storage  
冷却槽/工具箱



## Variable Speed Design Grinders / 调速砂轮机系列

### TECHNICAL FEATURES AND STANDARD FITTINGS

- Variable speed motor
- Industrial lamp (CSA only)
- Coolant tray
- Heavy cast iron base
- Cast aluminum angle adjustable work rest
- 无级调速马达
- 工业款灯罩 (CSA only)
- 冷却水槽
- 重型铸铁底座
- 铝压铸的角度可调工作台

### Technical Data/技术参数

Model/型号	WATT		$\phi$ mm		RPM		a x b x h mm		N.W./G.W. 净重/毛重	Container load/ 装柜数		
	Power/功率		Wheel size/砂轮尺寸		Motor speed/马达转速		Carton size/包装尺寸			Container load/ 装柜数		
	Watts (S1)	Watts (S2 30min)	MM	Inch	50Hz	60Hz	MM	KG		20 GP	40 GP	40 HP
TDS-G150V	180	300	150*20*12.7	6"3/4"1/2	60# / 36#	2000-2976	2000-3450	510*300*255	13.7 / 14.8	765	1530	1790
TDS-G200V	370	550	200*25*15.88	8"1/5/8	60# / 36#	2000-2976	2000-3450	540*330*290	17.7 / 19.2	444	900	1125
TDS-G150VLDB	180	300	150*20*12.7	6"3/4"1/2	36#	2000-2976	2000-3450	515*325*265	13.7 / 14.8	640	1272	1620
TDS-G200VLDB	370	550	200*25*15.88	8"1/5/8	36#	2000-2976	2000-3450	550*360*310	17.7 / 19.2	434	868	1024

# INDUSTRIAL BENCH GRINDER

# 工业款砂轮机

# SHARPENER 磨刀机系列

Bench Grinder $\phi$ 150mm/6inch <b>CH150A</b>		250 W	
Bench Grinder $\phi$ 175mm/7inch <b>CH175</b>		370 W	
Bench Grinder $\phi$ 200mm/8inch <b>CH200</b>		550 W	
Bench Grinder $\phi$ 250mm/10inch <b>CH250</b>		750 W	

## CH LINE BENCH GRINDER CH系列砂轮机特点

- Industrial standard bench grinder
- Equipped with a totally enclosed ball bearing motor.
- The armature assembly is dynamically balanced for smooth operation.
- The motor housing is compact so long pieces of work can press against both wheels without touching the motor frame.
- In build dust collection hose can connect with dust hose
- The tool rests are adjustable for wheel wear and angle grinding.

- 工业级品质砂轮机
- 带球轴承的全封闭马达
- 转子经过动平衡，保证平顺的操作性能
- 加长机身，在磨长工件时不会被电机干扰
- 机身自带吸尘管可连接集尘器
- 托架可调节前后和角度

Bench Grinder  $\phi$  300mm/ 12inch  
**CH300**



1100 W



Optional Work Stand  
可选支架



Angle Adjustable Work Rest  
角度可调的工作台

Heavy Duty Cast Iron Base  
强壮的铸铁底座



Dust Collection Hose  
集尘管



## Technical Data/技术参数

Model/型号	WATT		$\phi$ mm		RPM		a x b x h mm		Container load/装柜数			
	Power/功率		Wheel size/砂轮尺寸		Motor speed/马达转速		NW./G.W. 净重/毛重					
	Watts (S1)	Watts (S2 30min)	MM	Inch	50Hz	60Hz	MM	KG				
CH150A	150	250	150*20*12.7	6*3/4*1/2	36# / 60#	2980	3580	505*295*285	13.0 / 14.5	728	1424	1647
CH150B	250	370	150*25*12.7	6*1*1/2	36# / 60#	2980	3580	505*295*285	14.0 / 15.0	728	1424	1647
CH175	370	550	175*25*15.88	7*1*5/8	36# / 60#	2980	3580	595*395*410	22.3 / 24.0	270	535	642
CH200	550	750	200*25*15.88	8*1*5/8	36# / 60#	2980	3580	595*395*410	27.5 / 29.5	270	535	642
CH200T	550(400V)	750(400V)	200*25*15.88	8*1*5/8	36# / 60#	2980	3580	595*395*410	27.5 / 29.5	270	535	642
CH250	550	1100	250*25*20	10*1*3/4	36# / 60#	2980	1790	685*465*450	43 / 46	160	300	415
CH250T	450(400V)	900(400V)	250*25*20	10*1*3/4	36# / 60#	2980	1790	685*465*450	43 / 46	200	420	425
CH300	900 (P2)	1500(P2)	300*50*32	12*2*1-1/4	36# / 60#	1490	1790	wooden box 870*710*660	82 / 110	63	126	168

TDS-150EWG



400 W



Low speed wet sharpening  
低速湿磨

Dust proof switch  
防尘开关罩

Cast aluminum base  
铸铁底座

Optional LED light  
可选LED灯

High speed dry grinding  
高速干磨

## 8" x 6" Wet / Dry Grinder 干湿两用砂轮机

- Powerful induction motor delivers smooth, accurate results
- Eye shield protects you from flying debris without obstructing your view

- Coolant tray for cooling heated material
- Adjustable tool rests extend the life of the grinding wheels
- 200 mm wheel for wetstone application

- 动力充沛的感应马达保证了平顺和精确的磨削效果
- 护目镜保护你免受飞屑的伤害，不会影响视线
- 水槽可以冷却发热的工件
- 可调节的托架，延长砂轮片的使用寿命
- 200毫米的湿轮

TLG-150WG



250 W



Cast iron base  
铝压铸底座

## Technical Data/技术参数

Model/型号	WATT		$\phi$ mm		RPM	a x b x h mm		NW./G.W. 净重/毛重	Container load /装柜数						
	Power/功率		Dry wheel size/砂轮尺寸			Wet wheel size/砂轮尺寸									
	Watts (S1)	Watts (S2 30min)	MM	Inch		MM	Inch								
TDS-150EWG	250	400 (S2 10min)	150*20*12.7	6*3/4*1/2	60#	200*40*20	8*1-1/2*3/4	80#	2980/136	3580/162	485*330*365	11.5 / 13	480	1020	1176
TLG-150WG	180	250	150*20*12.7	6*3/4*1/2	60#	200*40*20	8*1-1/2*3/4	80#	2980/136	3580/162	485*330*365	12.8 / 13.5	480	1020	1176

## Low Speed Utility Blade Sharpener 低速多用磨刀机



SCM4500

80 W



- Two Side Cast Al Work Rest
- Two Sharpening Direction
- 120 Grit Wet / Dry sharpening stone
- 砂轮两端均有铝工作台
- 砂轮正反向转动
- 120粒度干湿两用磨刀轮

## Universal Sharpening Center 通用磨刀机



SCM5800

370 W



- High speed WA dry wheel
- Low speed wet wheel 320 #
- Height and angle adjustable cast iron work rest
- 高速白刚玉砂轮
- 320目低速湿轮
- 高度和角度可调的铸铁磨刀架

### Technical Data/技术参数

Model/型号	WATT		Dry wheel		Wet wheel		RPM		a x b x h mm						
	Power/功率		Dry wheel size/砂轮尺寸		Wet wheel size/砂轮尺寸		Motor speed /马达转速		Carton size /包装尺寸	N.W./G.W. 净重/毛重	Container load /装箱数				
	Watts (S1)	Watts (S2 30min)	MM	Inch	MM	Inch	50Hz	60Hz				MM	KG	20 GP	40 GP
SCM4500	50Hz:70W	N/A	N/A	N/A	N/A	118*38*14	4-1/2*1-1/2*9/16	120#	146	176	395*235*195	4.5 / 5	1529	3168	3718
SCM5800	250	370	125*50*12.7	5*2*1/2	80#	200*25*12.7	8*1*1/2	320#	2980/335	3580/394	500*355*330	15.5 / 17	518	1070	1192

## 8" Low Speed Sharpener 低速湿轮磨刀机



SCM8080

180 W



Honing Wheel  
抛光轮



Square Edge Jig  
直刀夹



Axe Jig  
斧头夹



Long Knife Jig  
长刀夹



Gouge Jig  
车刀夹

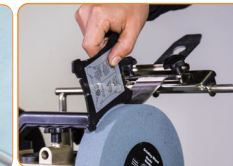

Angle Gauge  
角度规



Scissors Jig  
剪刀夹



Short Knife Jig  
短刀夹

- Gear Transmission Supply More Sharpening Torque
- Universal Sharpening Jigs Support
- 220 Grit WA Grinding Wheel
- Leather Stropping Wheel
- 齿轮传动提供更锋利的扭矩
- 万能磨具支架
- 220粒度白刚玉砂轮片
- 牛皮轮

### Technical Data/技术参数

Model/型号	WATT		Wet wheel		Dry wheel		RPM		a x b x h mm				
	Power/功率		Wet wheel size/砂轮尺寸		Dry wheel size/砂轮尺寸		Motor speed /马达转速		Carton size /包装尺寸	N.W./G.W. 净重/毛重	Container load /装箱数		
	Watts	HP	MM	Inch	MM	Inch	50Hz	60Hz				MM	KG
SCM8080	180	1/4	200*40*12	8*1-1/2*1/2	220#	200*30*12	8*1-1/5*1/2	95	115	380*365*345	10.5/ 11.8	576	1428
SCM8101	180	1/4	250*50*12	10*2*1/2	220#	200*30*12	8*1-1/5*1/2	95	115	390*375*355	15.3 / 16.5	576	1428

TLGS625



150 mm  
370 W

TLGS825



200 mm  
550 W



**BENCH GRINDER SANDER 砂轮砂带机**

- Combination machine include both grinding wheel and sanding belt.
- Eye shields protect you from flying debris without obstructing your view.
- Adjustable tool rests extend the life of the grinding wheels.
- Coolant tray for cooling heated material.
- 组合式机器，同时拥有砂轮和砂带
- 护目镜保护你免受飞屑的伤害，不会影响视线
- 可调节的托架，延长砂轮片的使用时间
- 水槽可以冷却发热的工件



**Flexible Light**  
可灵活转动的工作灯

Flexible work light illuminates the work space, promoting accurate sanding.



**Dust Collection Port**  
集尘器接口

The dust port clears dust from your work area.



**Sanding Belt Angle 0-90°**  
砂带可垂直或水平设置

Tilt the belt from a horizontal to a vertical position or anywhere in between depending on the needs of your project.



**Grinding Wheel**  
砂轮片

Equip with standard grinding wheel for fast grinding

TDS-150CSL



150 mm  
370 W



- Cast AL base
- Coolant tray
- Flexible work light
- 3 Times magnifier shield
- Quick belt release and easy tracking
- 铝压铸底座
- 冷却水槽
- 可灵活转动的工作灯
- 3倍放大护目镜
- 砂带快速拆卸及调整

TDS-150EBSL



150 mm  
400W



- Steel base
- Adjustable work rest and spark deflector
- Quick belt release and easy tracking
- 钢板底座
- 可调节的托架以及火花挡板
- 砂带快速拆卸及调整

HBGL650A



150 mm  
370 W



- Coolant tray
- Flexible light
- Quick wheel guard release system
- Streamlined double shield motor low surface temperature
- 冷却水槽
- 可灵活转动的工作灯
- 砂带快速拆卸及调整
- 低表面温度的流线型双层马达壳

**Technical Data 技术参数**

Model/型号	WATT		Ømm		mm x mm		grit / 粒度	Motor speed / 马达转速 RPM	Carton size / 包装尺寸 mm	N.W. / G.W. 净重 / 毛重 KG	Container load / 装箱数				
	Power/功率 Watts (S1)	Watts (S2 30min)	Dry wheel size/砂轮尺寸		Belt size/砂带尺寸						50Hz	60Hz	20 GP	40 GP	40 HP
			MM	Inch	MM	Inch									
TDS-150CSL	250	370	150*20*12.7	6*3/4*1/2	36#	50*686	2*27	80#	2980	3580	445*405*265	10.3 / 11.0	560	1160	1450
TDS-150EBSL	250	400	150*20*12.7	6*3/4*1/2	36#	50*686	2*27	80#	2980	3580	400*325*375	8.5 / 10.0	588	1206	1428
HBGL650A	250	370	150*20*12.7	6*3/4*1/2	36#	50*686	2*27	80#	2980	3580	445*395*245	9.8 / 10.5	675	1305	1450
TLGS625	250	370	150*20*12.7	6*3/4*1/2	60#	50*710	2*28	80#	2980	3580	450*410*295	12.6 / 13.3	560	1120	1260
TLGS825	370	550	200*20*15.88	8*3/4*5/8	60#	50*710	2*28	80#	2980	3580	450*385*345	16.3 / 17.5	450	900	1092

# INDUSTRIAL SANDER 工业款砂带机

## CH820S

-  200 mm
-  50 mm
-  550 W

- Cast iron base and belt frame
- Work rest tilts from 0° to 45°
- Full belt guard with dust collection port
- Belt is adjustable for use in vertical or horizontal position
- 铸铁底座和砂带床身
- 工作台0到45度可调
- 带排尘口的砂带护罩
- 砂带在0度或90度打磨







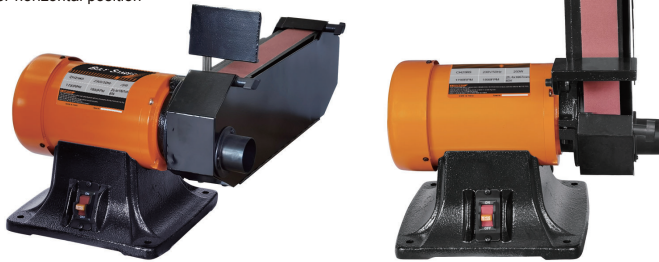

- |         |   |       |   |       |   |
|---------|---|-------|---|-------|---|
| CH25BS  |  | 25 mm |  | 250 W |  |
| CH50BS  |  | 50 mm |  | 550 W |  |
| CH100BS |  | 100mm |  | 550 W |  |







- Solid and powerful belt sander
- Work rest tilts from 0° to 45°
- Full belt guard with dust collection port
- Belt is adjustable for use in vertical or horizontal position
- 坚固大功率砂带机
- 工作台0到45度可调
- 带排尘口的砂带护罩
- 砂带在0度或90打磨



### Technical Data 技术参数

Model/型号	 WATT		 Ømm		 mm x mm		 RPM		 a x b x h mm						
	Power/功率	Watts	Dry wheel size/砂轮尺寸	grit/粒度	Belt size/砂带尺寸	grit/粒度	Motor speed/马达转速	Carton size/包装尺寸	N.W./G.W.净重/毛重	Container load/装柜数	20 GP	40 GP	40 HP		
CH820S	550W		200*25*15.88	60#	50*1220	80#	2980 3580	735*580*370	34 / 37	192	390	455			

Model/型号	 WATT		 mm x mm		 RPM		 a x b x h mm						
	Power/功率	Watts	Belt size/砂带尺寸	grit/粒度	Motor speed/马达转速	Linear speed/砂带线速度	Carton size/包装尺寸	N.W./G.W.净重/毛重	Container load/装柜数	20 GP	40 GP	40 HP	
CH25BS	250	25.4*1067	1*42	80#	1490 1790	7.5m/s 1800	695X465X345	21.5 / 24	246	498	580		
CH50BS	550	50*1220	2*48	80#	2980 3580	19m/s 4500	695X465X345	27.5 / 30	246	498	580		
CH100BS	550	100*915	4*36	80#	2980 3580	15m/s 3600	695X505X345	27 / 29	216	438	511		

# BUFFING MACHINE 抛光机

## TDS-75BR

-  75 mm
-  50 W









### Great Tool For Hobby Use

- Silence and free-maintenance induction motor
- Grinding wheel&wool buffing
- Multi function flexible shaft available
- PTO shaft and kits box available
- 安静, 免维护的感应马达
- 配砂轮和羊毛轮
- 可安装多功能软轴
- 可选配软轴附件包



### Technical Data/技术参数

Model/型号	 WATT		 Ømm		 RPM		 a x b x h mm						
	Power/功率	Watts	Buffing wheel size/布轮尺寸	grit/粒度	Motor speed/马达转速	Linear speed/布轮线速度	Carton size/包装尺寸	N.W./G.W.净重/毛重	Container load/装柜数	20 GP	40 GP	40 HP	
TDS-75B	35	50	75*13*10	80#	2980 3580	7.5m/s 1800	290*200*185(inner) 610*600*200(outer)	2.0 / 2.2 12.0 / 14.5	2844 297	5580 627	6664 741		
TLG-150BGA,C	180	250	150*8*12.7	80#	2980 3580	7.5m/s 1800	505*225*255	9.0 / 9.5	1062	2097	2380		
TLG-200BGA,C	250	370	200*10*15.88	80#	2980 3580	15m/s 3600	545*225*255	15.0 / 16.5	990	1944	2210		
TLG-150BGE	180	300	150*8*12.7	80#	1490 1790	7.5m/s 1800	505*225*255	9.0 / 9.5	1062	2097	2380		
TLG-200BGE	180	300	200*10*15.88	80#	1490 1790	15m/s 3600	545*225*255	15.0 / 16.5	990	1944	2210		

# BUFFING MACHINE 抛光机

TLG-150BGA / TLG-200BGA 

TLG-150BGB / TLG-200BGB 

 150 mm  200 mm

- 18Inch long shaft distance
- Heavy duty cast iron base for reducing vibration
- Powerful induction motor for reliable performance
- Two buffing wheels, including spiral sewn buffing wheel and Soft buffing wheel
- 457mm 长轴距
- 重型铸铁底座可减少机器震动
- 大功率感应马达
- 两个抛光轮, 包括一个多线布轮和一个软布轮



Low Speed Model  
TLG-150BGS  
TLG-200BGS



TDS-250BG / Single Speed 

TDS-250BGH / Two Speed

 150mm  300 W  
 200mm  300 W

 250 mm  750 W  
 250 mm  550 W / 750 W



- Powerful induction motor / 大功率感应马达
- Long shaft design / 加长工作轴
- Include spiral sewn buffing wheel and Soft buffing wheel
- 带一个多线布轮和一个软布轮

- Powerful induction motor / 大功率感应马达
- Long shaft design / 加长工作轴
- Two speed for multi application
- 双速设计满足不同需求 (TDS-250BGH)

## Technical Data/技术参数

Model/型号	WATT		mm		RPM		mm		kg		mm		
	Power/功率 Watts (S1)	Watts (S2 30min)	Buffing wheel size/布轮尺寸		Motor speed/马达转速		Carton size/包装尺寸		N.W./G.W. 净重/毛重		20 GP	40 GP	40 HP
			MM	Inch	50Hz	60Hz	MM	MM	KG				
TLG-150BGB	250	370	150*8*12.7	6*5/16*1/2	2980	3580	505*225*255	9.0 / 9.5	1062	2097	2380		
TLG-200BGB	370	550	200*10*15.88	8*3/8*5/8	2980	3580	545*225*255	15.0 / 16.5	990	1944	2210		
TDS-250BG	550	750	250*20*20	10*3/4*3/4	2980	3580	730*325*265	23.0 / 24.5	448	896	1120		
TDS-250BGH	550/750	N/A	250*20*20	10*3/4*3/4	1490/2850	1790/3580	730*325*265	23.0 / 24.5	448	896	1120		

# SANDING MACHINE 砂光机

6" DISC AND 4"X36" BELT SANDER 150\*100mm 砂盘砂带机 

MM491GL

 150 mm

 370 W

Angle Adjustable Belt

可调整的砂带  
Tilt the belt from a horizontal to a vertical position depending on the needs of your project.

Quick Sanding Belt Release

快速砂带涨紧  
Easy belt changing by pull the level

Sanding Belt Tracking

砂带位置调节  
Easy belt tracking by turn the knob

Aluminum work table with miter gauge

铝制工作台, 带角度规

Cast Iron Base

铸铁底座  
Cast iron base for low vibration

MM 491E 

 150 mm

 370 W

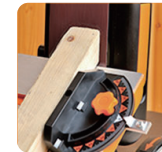

Belt Vertical use  
垂直使用砂带



Dust Collection Port  
集尘器接口



Belt sanding with Miter gauge  
砂带配合角度规使用



Driven Drum sanding  
从动滚筒打磨

Compair to Model MM493GL

- Heavy Duty Cast Iron Base  
重型铸铁底座
- Stable Work Table Support  
稳定的工作台支架

## Technical Data/技术参数

Model/型号	WATT		mm		mm x mm		mm		mm		mm		mm		mm		mm		mm				
	Power/功率 Watts	Motor Speed /马达转速	Disc Size/ 砂盘尺寸		Grit /粒度		Belt Size/ 砂带尺寸		Grit /粒度		Belt Speed /砂带速度		Table Title/ 工作台角度		Table Size/ 工作台尺寸		Carton size /包装尺寸		N.W./G.W. 净重/毛重		Container load /装箱数		
	50Hz	60Hz	MM	Inch	MM	Inch	MM	Inch	MM	Inch	50Hz	60Hz	°		Disc mm	Belt mm	MM		KG		20 GP	40 GP	40 HP
MM491GL	370	2980	3580	150	6	80#	100*915	4*36	80#	7.35	8.8	0 ~ 45°	225*160	NA	565*280*330	16.5 / 18.0	560	1120	1270	505	1008	1008	
MM491E	370	2980	3580	150	6	80#	100*914	4*36	80#	7.35	8.8	0 ~ 45°	215*146	NA	565*320*345	20.0 / 21.5	505	1008	1008				

## BD4602



150 mm  
370 W

### 6" DISC AND 4"X36" BELT SANDER

- Position Adjustable Sanding Belt from 0-90degree
- Adjustable work table 0-45 degree with mitre gauge
- Multi wedge belt drive mechanism
- Separate dust exhaust for disc and belt
- Quick belt release and easy tracking
- 砂带在0度或90度打磨
- 带角度规的工作台0到45度可调
- 多楔带传动
- 砂盘和砂带排尘分离
- 砂带快速拆卸及调整



## MM493B



125 mm  
250 W

### 5" DISC AND 1"X30" BELT SANDER

#### Enclosed Induction Motor

- 封闭式感应马达
- Induction motor delivers powerful, quiet, dependable performance.
- 感应电动机提供强大、安静、可靠的性能。

#### Cast Aluminum Base

- 铝压铸底座
- The cast AL base keeps the sander stable during use, so you can apply the desired amount of pressure and achieve consistent results.
- 铝压铸底座让砂带机在工作时保持稳定，这样可以任意施加压力来得到想要的抛磨效果。
- Belt fast tracking
- 砂带快速调整
- Cast Al work rest with mitre gauge
- 铸铝工作台带角度规



## BD1600VS



150 mm  
550 W

### Vario Speed 6" Disc & 1"X30" Belt Sander

- Vertical belt sanding with table or workstop
- Sand true, straight edges, end grain and flat surfaces
- Disc sanding with table and miter-gauge
- Sand at any angle with miter-gauge
- Sand flat or angled ends, edges or flat surfaces
- 砂带垂直，配合工作台或者限位板使用
- 打磨直角，端面和平面
- 配合工作台和分度盘使用砂盘进行打磨
- 使用分度盘打磨各种角度
- 打磨平的或者带角度的物料端面，角度或者平面



## BD4800



200 mm  
500 W

### 8" DISC AND 4"X36" BELT SANDER

Sanding belt and disc were directly driven by motor shaft, no belt, no gears. Maintenance-free  
砂带和砂盘均为马达直接驱动，没有皮带齿轮等传动机构，免维护

- Total enclosed motor
- Cast Al work table for both sanding belt and disc
- 全封闭马达
- 砂带和砂盘均配有铝压铸工作台



### Technical Data/技术参数

Model/型号	Power/功率	Motor Speed/马达转速	Disc Size/砂盘尺寸	Grit/粒度	Belt Size/砂带尺寸	Grit/粒度	Belt Speed/砂带速度	Table Tilt/工作台角度	Table Size/工作台尺寸	Carton size/包装尺寸	N.W./G.W.净重/毛重	Container load/装柜数
	Watts	50Hz 60Hz	MM Inch	MM Inch	MM Inch	50Hz 60Hz	°	Disc mm Belt mm	MM	MM	KG	20 GP 40 GP 40 HP
BD4602	370	2980 3580	150 6	80#	100*915 4*36	80#	7.4 8.8	0 ~ 45°	202*136 NA	515*320*330	11.5 / 12.7	546 1113 1304
MM493B	250	2980 3580	125 5	80#	25.4*762 1*30	100#	14 17	0 ~ 45°	185*98 φ148	445*310*300	7.3 / 8.8	650 1300 1500

### Technical Data/技术参数

Model/型号	Power/功率	Motor Speed/马达转速	Disc Size/砂盘尺寸	Grit/粒度	Belt Size/砂带尺寸	Grit/粒度	Belt Speed/砂带速度	Table Tilt/工作台角度	Table Size/工作台尺寸	Carton size/包装尺寸	N.W./G.W.净重/毛重	Container load/装柜数
	Watts	50Hz 60Hz	MM Inch	MM Inch	MM Inch	50Hz 60Hz	°	Disc mm Belt mm	MM	MM	KG	20 GP 40 GP 40 HP
BD1600VS	550	2000-2980 2000-3400	150 6	80#	25.4*762 1*30	100#	9.6-13.7 9.6-16.4	0 ~ 45°	204*156 φ148	480*420*335	13.5 / 15.0	440 900 1000
BD4800	500	2980 3580	200 8	80#	100*914 4*36	80#	9.2 11	0 ~ 45°	264*150 170*125	585*515*380	21 / 24	252 516 616

**BD4603**



150 mm  
450 W



**BD4801**



200 mm  
500 W



## DIRECTLY DRIVEN BELT DISC SANDER 马达直驱砂带砂盘机

6" DISC AND 4"×36" BELT SANDER | 8" DISC AND 4"×36" BELT SANDER

- Sanding belt and disc were directly driven by a powerful 450w/500w motor , provides power for small and large sanding operations on various materials.
- 砂带和砂盘均为强劲的450瓦/500瓦马达直接驱动，为各种尺寸材料的砂光工作提供动力
- Sanding belt tilts up to 90 degrees vertical, unsupported underside allows for sanding of curved work pieces.
- 砂带可90度直立使用，没有支撑的背面，可以用来磨有弧度的工件
- No drive belt , No gears, Maintenance-free
- 没有皮带齿轮等传动机构，免维护



- Quick sanding belt release and track
- With support for belt sanding
- Large AL table which can adjust from 0-45° degree.
- work table used on sanding belt
- Separated dust port for both belt and disc sanding.
- 快速砂带更换及位置调整
- 配有砂带支撑
- 0-45°可调整的宽大铝工作台
- 工作台配合砂带使用
- 砂带和砂盘部分都有排尘口

### Technical Data/技术参数

Model/型号	Power / 功率		Motor Speed / 马达转速		Disc Size/ 砂盘尺寸		Belt Size/ 砂带尺寸		Belt Speed / 砂带速度		Table Tilt/ 工作台角度		Table Size/ 工作台尺寸		Carton size / 包装尺寸		N.W./G.W. 净重/毛重		Container load / 装柜数	
	Watts	50Hz	60Hz	50Hz	60Hz	MM	Inch	MM	Inch	50Hz	60Hz	°	Disc mm	Belt mm	MM	KG	20 GP	40 GP	40 HP	
BD4603	450	2980	3580	150	6	80#	100*914	4*36	80#	9.2	11	0~45°	195*136	NA	565*500*250	13.3 / 15.0	390	820	920	
BD4801	500	2980	3580	200	8	80#	100*914	4*36	80#	9.2	11	0~45°	264*150	190*160	575*515*285	15.0 / 16.5	350	700	790	

**BD1800**



200 mm  
250 W



## 8" DISC AND 1"×42" BELT SANDER

- Powerful induction motor
- Cast iron belt frame
- Cast iron work rest with miter gauge
- Two 2" dust port more easy connection to a shop vacuum or dust collector.
- 大功率感应马达
- 铸铁砂带座
- 铸铁工作台带角度规
- 2个集尘口更容易连接到车间吸尘器或除尘器

**BD2601**



150 mm  
370 W

## 6" DISC AND 2"×42" BELT SANDER

This belt and disc sander has a 2x42" belt and 6"disc for deburring , beveling and sanding wood , plastic and metal The belt table tilts 0-60° degree and the disc table tilts 0 to 45 degree for angle sanding . The quick release tension and tracking mechanism makes belt changing quick and easy 这台砂光机装配有2x42寸的砂带和6寸的砂盘，用来去除木材，塑料，金属的毛刺，打磨斜边和砂光表面。砂带工作台可以0-60度调整，砂盘工作台可以0-45度调整。快速涨紧和砂带调节机构方便更换和调整砂带

Belt plate is removable for contour sanding . Belt housing swivels from horizontal to vertical for sanding long work pieces 砂带挡板可以拆卸，用来进行轮廓的打磨。砂带部分可以垂直到水平调节，方便打磨长的工件



### Technical Data/技术参数

Model/型号	Power / 功率		Motor Speed / 马达转速		Disc Size/ 砂盘尺寸		Belt Size/ 砂带尺寸		Belt Speed / 砂带速度		Table Tilt/ 工作台角度		Table Size/ 工作台尺寸		Carton size / 包装尺寸		N.W./G.W. 净重/毛重		Container load / 装柜数	
	Watts	50Hz	60Hz	50Hz	60Hz	MM	Inch	MM	Inch	50Hz	60Hz	°	Disc mm	Belt mm	MM	KG	20 GP	40 GP	40 HP	
BD1800	250	1490	1790	200	8	80#	25.4*1067	1*42	80#	13	15.6	0~45°	102*250	152*178	535*345*405	27.0 / 28.5	360	720	860	
BD2601	370	2980	3580	150	6	80#	51*1067	2*42	80#	8.5	22	0~45°	204*156	228.5*170	605*440*280	14.5 / 16.0	390	790	890	



## CH6900BD



- 229 mm
- 1000 W



### 9" DISC AND 6"×48" BELT SANDER

- Belt Operates in Vertical or Horizontal Position.
- Quick Release Tension Mechanism for Fast Easy Belt Changes.
- Both Belt and Disc Come with Tilting Table, Miter Gauge
- Open Floor Stand
- 砂带部分可在0度或90度打磨
- 快速砂带涨紧结构
- 可调节角度工作台，带分度盘（砂盘和砂带均可使用）
- 开放式支架

## BD61000



- 250 mm
- 750 W



### 9"/10" DISC AND 6"×48" BELT SANDER

- Powerful induction motor
- Cast AL work table with miter gauge
- Rigid steel base, light weight
- Optional stand
- 大功率感应马达
- 带角度规的铝压铸工作台
- 牢固的钢板底座，轻量化设计
- 支架可选

## BD6900



- 229 mm
- 750 W



## DS-12B



- 305 mm
- 900 W

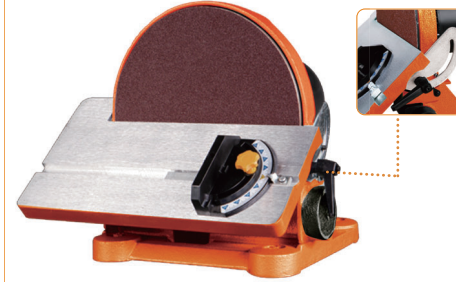

- Cast Aluminum work table with miter gauge
- Cast iron TEFC motor
- Heavy duty cast iron frame and base
- In- built dust ex-blower design
- 铝压铸工作台，带分度盘
- 全封闭风冷的铸铁壳马达
- 重型铸铁机身和底座
- 内置的灰尘外排设计

## DS-12D



- 305 mm
- 900 W

Disc brake system available  
可选砂盘快速刹车系统



## DS-12F



- 305 mm
- 800 W

### 12" DISC SANDER

- Steel motor
- Disc brake system available
- Cast Aluminum work table with miter gauge
- Heavy duty cast iron frame and base
- 钢板壳电机
- 可选砂盘快速刹车系统
- 铝压铸工作台，带分度盘
- 重型铸铁机身和底座



Disc guard available  
可选砂盘防护罩

### Technical Data/技术参数

Model/型号	WATT		RPM		Disc Size/砂盘尺寸		Grit/粒度		Belt Size/砂带尺寸		Grit/粒度		Belt Speed/砂带速度		Table Title/工作台角度		Table Size/工作台尺寸		Carton size/包装尺寸		N.W./G.W. 净重/毛重		Container load/装柜数	
	Power/功率	Watts	50Hz	60Hz	MM	Inch	MM	Inch	MM	Inch	50Hz	60Hz	°	Disc mm	Belt mm	MM	KG	20 GP	40 GP	40 HP				
BD6900	750	2980	2980	3580	229	9	80#	150*1220	6*48	80#	8	9.6	0~45°	295*150	NA	750*455*470	30.0 / 32.5	190	380	380				
CH6900BD	1000	2980	2980	3580	229	9	80#	150*1220	6*48	80#	11.3	13.5	0~45°	295*150	NA	720*630*345	45 / 49.5	193	401	451				
BD61000	750	2980	2980	3580	250	10	80#	150*1220	6*48	80#	8	9.6	0~45°	332.5*170	NA	750*455*470	39.5 / 42.5	190	380	380				
DS-12B	900	1490	1790	305	12	80#	NA	NA	NA	NA	NA	NA	0~45°	417*174	NA	480*455*425	35.0 / 37.0	300	600	730				
DS-12D	900	1490	1790	305	12	80#	NA	NA	NA	NA	NA	NA	0~45°	438*156	NA	480*455*425	30.0 / 32.0	300	600	730				
DS-12F	800	1490	1790	305	12	80#	NA	NA	NA	NA	NA	NA	0~45°	417*174	NA	480*455*425	28.0 / 30.0	300	600	730				

## Orbital Floor Sander 地板抛光机

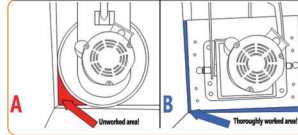
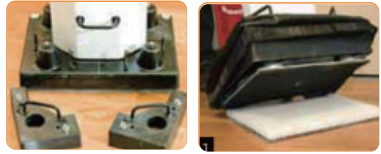

The square buffer's shape allows it to clean corners against baseboards unlike radial buffers seen in left pic.

### FS-B

- Auto Dust Collection
- Rectangle sanding
- 自动吸尘
- 矩形砂磨

## Floor scraper 铲地板机

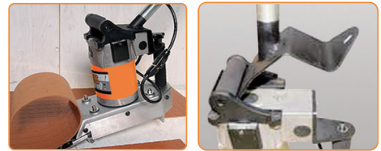

### FS-A

- Detachable handle
- Cast Al frame, light weight and strong
- 可拆卸的操作杆
- 铝压铸机身, 轻便, 强壮

### Technical Data/技术参数

Model/型号	Power/功率		Motor speed/马达转速		Working parts/工作部件	Working parts material/工作件材料	Optional parts/可选件	Feature/特性	Carton size/包装尺寸	N.W./G.W.净重/毛重	Container load/装箱数		
	Watts (S1)	Watts (S2 30min)	50Hz	60Hz							MM	KG	20 GP
FS-A	180	300	4450	4450	Blades	65 Mn Blade	Extension Handle	Orbital Cutting	Tool: 380x164x380 Handle: 1030x210x98	650 / 1300 / 1500	650	1300	1500
FS-B	1100	NA	2980	3580	Sanding Pad & Paper	#80 Al Oxide Paper or Silicon Carbide Net Size: 445x300x25mm	Cleaning Pad & Wire Net	Rectangle Orbital Sanding & Auto Dust Collection	Tool: 535x470x525 Handle: 960x460x135	55 / 58	145	290	350

## GS-A

- Base
- Large steel table
- Power hook
- 底座
- 宽大的钢板平台
- 电源线挂钩



## GS-B

Water tank  
冷却水槽



## GS-C

- Cast iron base
- Steel frame
- Water tank/tool box
- Wheel storage
- 铸铁底座
- 钢板机身
- 冷却水槽/工具箱
- 砂轮片储藏位



## GS-E

Height adjustable  
高度可调  
710-910 mm

- Cast iron base
- Large steel table
- Water tank/tool box
- Wheel storage
- 铸铁底座
- 宽大的钢板平台
- 冷却水槽/工具箱
- 砂轮片储藏位



### Technical Data/技术参数

型号 Model	高度 Height (mm)	工作台尺寸 Table Size (mm)	平台材料 Table Material	支柱材料 Pipe Material	底座尺寸 Base Size (mm)	底座材料 Base Material	通用砂轮机 Applicable Grinders Size	砂轮存放盒 Grinding Wheel Storage	水槽 Water Tank	包装尺寸 Carton size (mm)	净重/毛重 N.W./G.W. (Kg)	装箱数 Container load		
												20GP	40GP	40HP
GS-A	812	315*250	钢板 Steel Metal	钢管 Steel Pipe	φ478	铸铁 Cast Iron	125mm-250mm	No	可选配 Optional	825*395*125	9 / 10	630	1290	1510
GS-B	812	315*250	钢板 Steel Metal	钢管 Steel Pipe	φ478	铸铁 Cast Iron	125mm-250mm	No	可选配 Optional	825*395*125	10 / 11	630	1290	1510
GS-C	760	280*170	钢板 Steel Metal	铁皮 Sheet Metal	φ344	铸铁 Cast Iron	125mm-250mm	Yes	Yes	815*370*260	12 / 13.5	385	780	870
GS-E	710-910	315*250	钢板 Steel Metal	钢管 Steel Pipe	φ478	铸铁 Cast Iron	125mm-250mm	Yes	Yes	645*555*135	8.2 / 10	610	1220	1400

With Sheet Metal Work Table and Base

DP8A

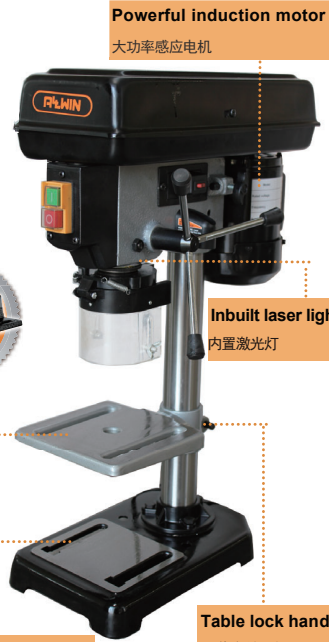

Powerful induction motor  
大功率感应电机

Inbuilt laser light  
内置激光灯

Steel work table & Base  
铁板工作台和底座

Table lock handle  
工作台锁紧把手

With Cast Iron Work Table and Base

DP8



Safety guard  
钻头防护罩

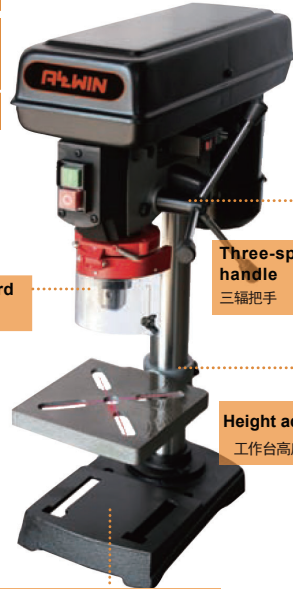

Three-spoke feed handle  
三辐把手

Height adjustment  
工作台高度可调

Sturdy cast iron base & Table  
铸铁底座

DP8F



MACHINE HEIGHT  
1580mm

CROSS LASER



FLOOR MODEL DRILL PRESS  
落地型台钻

- Three-spoke Feed Handle
- Sturdy cast iron base
- Cross laser guided ( optional )
- Optional steel or cast iron work table
- 三辐把手
- 稳固的铸铁底座
- 交叉激光指示 (可选)
- 可选钢板或铸铁工作台

DP2501A / DP2501B

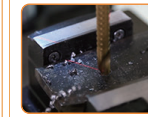

Precision laser  
交叉激光指示



Optional plastic pulley guard  
可选塑料皮带罩



Angle adjustable work table  
倾斜的工作台



BENCH TOP DRILL PRESS  
桌面型台钻

- Safety guard
- Three-spoke feed handle
- Powerful induction motor
- Cast iron work table angle adjustable
- Rack&pinion for accurate table height adjustments
- Sturdy cast iron base
- NVR switch,safety guard as CE requirement
- Emergency stop as GS requirement
- 电磁开关, 钻头防护罩为 CE 安规要求
- 急停按钮为GS 认证要求
- 钻头防护罩
- 三辐把手
- 大功率感应电机
- 铸铁工作台角度可调
- 高度通过齿轮齿条调节
- 稳固的铸铁底座



Keyed Chuck  
13mm/16mm  
夹头

Onboard Key Storage  
夹头钥匙槽

High Quality Drive Pulley with 5 Step  
5速可调

Precision Laser  
激光导视系统

Drilling Depth Adjustment System  
钻孔深度可调

## Technical Data/技术参数

Model 型号	WATT		RPM		Max Chuck capacity 最大夹头尺寸	Spindel travel 主轴行程	Taper 主轴锥度	No. of speed 速度数量	Speed range 速度范围		Swing 旋转直径	Table size 工作台尺寸	Table Tilt 工作角度	Column Dia. 立柱直径	Base size 底座尺寸	Machine Height 机器高度	Carton size 包装尺寸	N.W./G.W. 净重/毛重	Container load 装箱数								
	Watts S1	Watts S2	50Hz	60Hz					mm	inch									mm	mm	mm	mm	mm	kg	20 GP	40 GP	40 HP
	15min																										
DP8A	250	500	1490	1790	φ13 or φ16	50	JT33/B16	5	550-2500	750-3200	200	8	164x162	45-0-45	46	298x190	580	485x370x240	13.5/15.5	715	1435	1755					
DP8	250	350	1490	1790	φ13 or φ16	50	JT33/B16	5	550-2500	750-3200	200	8	165x165	45-0-45	46	276x178	580	460x420x240	14.4/15.5	630	1260	1400					

## Technical Data/技术参数

Model 型号	WATT		RPM		Max Chuck capacity 最大夹头尺寸	Spindel travel 主轴行程	Taper 主轴锥度	No. of speed 速度数量	Speed range 速度范围		Swing 旋转直径	Table size 工作台尺寸	Table Tilt 工作角度	Column Dia. 立柱直径	Base size 底座尺寸	Machine Height 机器高度	Carton size 包装尺寸	N.W./G.W. 净重/毛重	Container load 装箱数								
	Watts S1	Watts S2	50Hz	60Hz					mm	inch									mm	mm	mm	mm	mm	kg	20 GP	40 GP	40 HP
	15min																										
DP8F	250	500 (15min)	1490	1790	φ13 or φ16	50	JT33/B16	5	550-2500	750-3200	200	8	165x165	45-0-45	46	440x300	1580	1150x390x260	22.7 / 27.0	270	540	600					
DP2501A/B	390	550 (10min)	1490	1790	φ13 or φ16	50	JT33	5	510-2430	610-2850	250	10	194x165	45-0-45	48	341x208	730	620x390x310	22.5 / 24.0	378	790	872					

PROFESSIONAL BENCH TOP DRILL PRESS

专业桌面型台钻

**DP25016**



16 mm



12 Speed

**DP25013**



13 mm



5 Speed

**SWING 10 INCH**



**Powerful induction motor**  
大功率感应电机

**NVR switch with emergency stop**  
带急停盖的电磁开关

**Safety guard**  
钻头防护罩

**Cast iron work table**  
铸铁工作台

**Sturdy cast iron base**  
铸铁底座

**Three-spoke feed Handle**  
三辐把手

**Rack&pinion for accurate table height adjustments**  
高度通过齿轮齿条调节

FLOOR MODEL DRILL PRESS  
落地型台钻

**DP34016F**

**SWING 13 INCH**



20 mm



12 Speed

**MACHINE HEIGHT**  
1610mm

- Rack&Pinion for accurate table height adjustments
- Cast iron work table bevel 45° left and right, 360° rotation
- Floor or Bench top
- 高度通过齿轮齿条调节
- 铸铁工作台左右45°可调, 360°旋转
- 可选台式款和立式款



BENCH TOP DRILL PRESS  
桌面型台钻

**DP13B**

**SWING 13 INCH**



20 mm



12 Speed

**MACHINE HEIGHT**  
1065mm



FLOOR MODEL DRILL PRESS

落地型台钻

**DP39020F**

**SWING 15 INCH**



20 mm



12 Speed

**MACHINE HEIGHT**  
1630mm



- 12 Speed for different application
- Cross laser guided ( optional )
- Dual voltage design
- Sturdy cast iron base
- 12种速度用于钻不同的材料
- 交叉激光指示(可选)
- 双电压马达设计
- 稳固的铸铁底座



FLOOR MODEL DRILL PRESS

落地型台钻

**DP43028F**

**SWING 17 INCH**



25 mm



16 Speed

**MACHINE HEIGHT**  
1635mm

**High quality drive pulley with 16 speed**  
高质量的塔轮, 带16档调速

- Cast iron main head, work table and base
- 铸铁主头、工作台和底座



**DP51532F**

**SWING 20 INCH**



32 mm



12 Speed

**MACHINE HEIGHT**  
1700mm



Technical Data/技术参数

Model 型号	WATT		RPM		Max Chuck capacity 最大夹头尺寸	Spindel travel 主轴行程	Taper 主锥度	No. of speed 速度数量	Speed range 速度范围		Swing 旋转直径	Table size 工作台尺寸	Table Title 工作角度	Column Dia. 立柱直径	Base size 底座尺寸	Machine Height 机高	Carton size 包装尺寸	N.W./G.W. 净重/毛重	Container load 装箱数													
	Watts S1	Watts S2 10min	50Hz	60Hz					50Hz	60Hz										mm	inch	mm	mm	mm	mm	mm	mm	mm	mm	mm	mm	mm
DP25013	390	550	1490	1790	φ13	60	JT33/B16	5	510-2430	310-2850	250	10	190x190	45-0-45	59.5	341x208	870	710x490x280	27.0 / 29.0	296	584	657										
DP25016	550	N/A	1490	1790	φ16	60	JT33/B16	12	230-2470	280-3000	250	10	190x190	45-0-45	59.5	341x208	870	710x490x280	27.0 / 29.0	296	584	657										
DP34016F	550	N/A	1490	1790	φ20	80	JT33/B16	12	280-3000	310-3600	340	13	255x255	45-0-45	70	428x255	1600	1400x494x245	51.0 / 56.0	144	188	320										
DP13B	550	N/A	1490	1790	φ20	80	JT33/B16	12	260-3000	310-3600	340	13	255x255	45-0-45	70	428x255	1065	850x505x320	35.0 / 38.0	203	413	472										

Technical Data/技术参数

Model 型号	WATT		RPM		Max Chuck capacity 最大夹头尺寸	Spindel travel 主轴行程	Taper 主锥度	No. of speed 速度数量	Speed range 速度范围		Swing 旋转直径	Table size 工作台尺寸	Table Title 工作角度	Column Dia. 立柱直径	Base size 底座尺寸	Machine Height 机高	Carton size 包装尺寸	N.W./G.W. 净重/毛重	Container load 装箱数												
	Watts S1	Watts S2 10min	50Hz	60Hz					50Hz	60Hz										mm	inch	mm	mm	mm	mm	mm	mm	mm	mm	mm	mm
DP39020F	750	1490	1790	φ20	100	JT33/B16	12	260-3000	310-3600	380	15	293x293	45-0-45	70	535x380	1630	1440x570x320	69.0 / 73.0	112	224	256										
DP43028F	900	1490	1790	φ25	80	MT3/B22	16	170-3000	200-3630	430	17	335x335	45-0-45	80	535x380	1630	1450*610*310	74.0 / 78.0	91	189	216										
DP51532F	1100	1490	1790	φ32	120	MT3/B22	12	200-2000	240-2400	515	20	425x475	45-0-45	92	610x460	1700	1150*643*310 850*520*320	75.0 / 78.0 83.0 / 86.0	85	170	190										

# VARIABLE SPEED DRILL PRESS 调速台钻

# VARIABLE SPEED DRILL PRESS 调速台钻

DP30016VL



SWING  
12 INCH



20 mm



In built LED light  
内置LED灯



Heavy Duty Metalworking  
Drilling Table w/ Extension  
Support  
带延伸支撑的重型金工作台



Optional wood working  
iron work table  
可选木工工作台

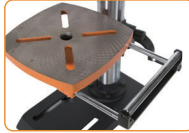

Table roller extension  
工作台可延长  
Extend the table roller for up  
to 17 inches of support for  
your workpiece.



Mechanical speed  
adjustment  
无极调速



## Better Performance Variable Speed Design 性能出众的无级调速设计

- Powerful induction motor
- Variable speed changing, no need open belt cover
- Cross laser guided
- Rack&pinion for accurate table height adjustments
- 大功率感应电机
- 无极调速设计, 调节转速而不需打开皮带罩
- 交叉激光指示
- 高度通过齿轮齿条调节

## Technical Data/技术参数

Model 型号	WATT		RPM		Max Chuck capacity 最大夹头尺寸 mm	Spindel travel 主轴行程 mm	Taper 主锥角度	No. of speed 速度数量	Speed range 速度范围		Swing 旋转直径 mm	Table size 工作台尺寸 mm	Table Title 工作角度	Column Dia. 立柱直径 mm	Base size 底座尺寸 mm	Machine Height 机器高度 mm	Carton size 包装尺寸 mm	N.W./G.W. 净重/毛重 kg	20 GP	40 GP	40 HP	Container load
	Watts S1	Watts S2(15min)	50Hz	60Hz					50Hz	60Hz												
DP25013VL	390	550 (S210min)	1490	1790	φ13	50	JT33/B16	VS	440-2580	500-3100	250	10	194x165	-45-0-45	48	341x208	730	620x420x310	22.5 / 24.0	378	790	872
DP25016VL	390/ 550	N/A	1490	1790	φ16	80	JT33/B16	VS	440-2580	500-3100	250	10	190x190	-45-0-45	59.5	341x208	870	710x480x280	27.0 / 29.0	296	584	657
DP30016VL	550	N/A	1490	1790	φ20	80	JT33/B16	VS	450-2580	530-3100	300	12	240x240	-45-0-45	65	410x250	950	750x505x295	38.5 / 41.0	230	460	550
DP15VL	750	N/A	1490	1790	φ20	100	JT33/B16	VS	240-2750	280-3300	380	15	306x306	-45-0-45	73	535x380	1650	1440x570x320	70.0 / 75.0	112	224	256

DP25013VL / DP25016VL



SWING  
10 INCH



13/16 mm



Mechanical speed adjustment  
无极调速  
Adjust the speed as needed with a simple  
move of the lever and receive the same  
power and torque through the entire speed  
range.

## Better Performance Variable Speed Design 性能出众的无级调速设计

- Powerful induction motor
- Variable speed changing, no need open belt cover
- Cross laser guided
- Rack&pinion for accurate table height adjustments
- 大功率感应电机
- 无极调速设计, 调节转速而不需打开皮带罩
- 交叉激光指示
- 高度通过齿轮齿条调节



DP15VL



SWING  
15 INCH



16 mm



## Better Performance Variable Speed Design 性能出众的无级调速设计

- Variable speed for different application
- Industrial goose nick lamp ( optional )
- Cross laser guided ( optional )
- Rack&pinion for accurate table height adjustments
- Sturdy cast iron base
- 多种速度用于钻不同的材料
- 弯管大灯 (可选)
- 交叉激光指示 (可选)
- 高度通过齿轮齿条调节
- 稳固的铸铁底座



## 5 Speed Radial Drill Press 5速变径台钻

### DP16R / DP16RA

-   
1-16 mm
- SWING**
- 240-420mm



- This 5-speed radial drill press features variable swing up to 420mm and pivoting heads for drilling at just about any angle.
- Cast iron Base with extension support
- 5 Speeds for different application
- Adjustable swing up to 420mm
- 这款5速变径台钻可以提供420m m的最大钻孔直径，可以在各种角度进行钻孔。
- 铸铁底座带延长支撑
- 5种转速可调
- 旋径可调节至420m m

### Technical Data/技术参数

Model 型号	Power 功率 Watts S1	Motor speed 马达转速 50Hz 60Hz	Max Chuck capacity 最大夹头尺寸 mm	Spindel travel 主轴行程 mm	Taper 主轴锥度	No. of speed 速度数量	Speed range 速度范围 50Hz 60Hz	Swing 旋转直径 mm	Table size 工作台尺寸 mm	Table Tilt 工作角度	Column Dia. 立柱直径 mm	Base size 底座尺寸 mm	Machine Height 机器高度 mm	Carton size 包装尺寸 a x b x h mm	N.W./G.W. 净重/毛重 kg	20 GP 装箱数	40 GP 装箱数	40 HP 装箱数	
DP16R	550	1490 1790	φ16	80	JT33/MT2	5	416-2400	500-2920	280-840	220x230	-45°-0°-45°	60	340x215	800	900*460*320	37.0 / 40.0	224	455	520
DP16RA	550	1490 1790	φ16	80	JT22/MT2	5	416-2400	500-2920	280-840	φ290	-45°-0°-45°	60	420x246	1638	1420*500*260	55.0 / 58.0	144	288	320

## SSA16V



406 mm

50 mm

125 W

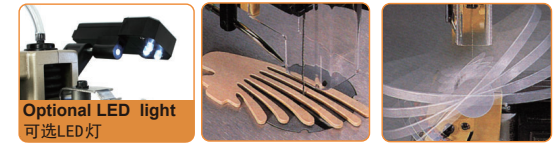

Optional LED light  
可选LED灯

### 16" SCROLL SAW

- Cast iron base ,low vibration
- 406mm cutting capacity
- Variable speed control for cutting wood and plastic
- In-built dust blower
- Table adjustable 0-45°
- Pinless blade holder
- Optional Steel work table
- 铸铁底座，低振动
- 切割板材直径度406m m
- 切割速度可调用于切割木材或塑料
- 带鼓风机
- 工作台角度可调
- 可使用无销锯条
- 可选钢板工作台



## SSA16AL



406 mm

50 mm

125 W



### 16" SCROLL SAW WITH LIGHT

- Optional LED light (Flexible or Fix )
- 12V/10W Flexible working light
- Cast iron base ,low vibration
- 406mm cutting capacity
- Variable speed control for cutting wood and plastic
- In-built dust blower
- Table adjustable 0-45°
- Pinless blade holder
- 可选LED 灯，弯管式或者固定式
- 可灵活转动的12伏/10瓦白炽灯
- 铸铁底座，低振动
- 切割板材直径度406m m
- 切割速度可调用于切割木材或塑料
- 带鼓风机
- 工作台角度可调



SSA16TL



406 mm

50 mm



125 W



Toolless blade clamp  
免工具锯条夹持



Quick side cover open  
侧盖板快速打开

16" SCROLL SAW WITH LIGHT

- Optional LED light (Flexible or Fixed )
- Cast iron base ,low vibration
- 406mm cutting capacity
- Variable speed control for cutting wood and plastic
- In-built dust blower
- Table adjustable 0-45°
- Pinless blade holder
- Change the blade quickly with holder and side cover handles

- 可选LED 灯, 弯管式或者固定式
- 铸铁底座, 低振动
- 切割板材直径度406mm
- 切割速度可调用于切割木材或塑料
- 带鼓风机
- 工作台角度可调
- 可使用无销锯条
- 可用把手快速更换锯条

Technical Data/技术参数

Model/ 型号	WATT			Max cutting depth 最大切割厚度		Max cutting size 最大切割半径		S.P.M	Table size 工作台尺寸	Table tilt 工作角度	Blade size 锯条尺寸	Flexible shaft speed/ 软轴速度	Carton size 包装尺寸	N.W. / G.W. 净重/毛重	Container load 装箱数		
	Watts S1	Watts S2 30min	Watts S2 5min	mm at 0°	mm at 45°	mm	inch								SPM	mm	mm
SSA16V	70	90	125	50	20	406	16	550-1600	414x254	0-45°	133x3x0.5	N/A	675x330x375	10.5 / 12.0	350	730	845
SSA16TL	70	90	125	50	20	406	16	550-1600	414x254	0-45°	133x3x0.5	N/A	675x330x375	11.0 / 12.5	335	690	720
SSA16AL	70	90	125	50	20	406	16	550-1600	414x254	0-45°	133x3x0.5	N/A	675x330x400	11.0 / 12.5	335	690	720

SSA16ALR



406 mm

50 mm



125 W



Safety guard  
安全护罩

Miter gauge  
分度盘

16" SCROLL SAW WITH PTO SHAFT

- 12V/10W flexible working light
- PTO shaft
- Cast iron base ,low vibration
- 406mm cutting capacity
- Variable speed control for cutting wood and plastic
- In-built dust blower
- Table adjustable 0-45°
- Pinless blade holder

- 可灵活转动的12伏 / 10瓦白炽灯
- 可连接多功能软轴
- 铸铁底座, 低振动
- 切割板材直径度406mm
- 切割速度可调用于切割木材或塑料
- 带鼓风机
- 工作台角度可调
- 可使用无销锯条



Technical Data/技术参数

Model/ 型号	WATT			Max cutting depth 最大切割厚度		Max cutting size 最大切割半径		S.P.M	Table size 工作台尺寸	Table tilt 工作角度	Blade size 锯条尺寸	Flexible shaft speed/ 软轴速度	Carton size 包装尺寸	N.W. / G.W. 净重/毛重	Container load 装箱数		
	Watts S1	Watts S2 30min	Watts S2 5min	mm at 0°	mm at 45°	mm	inch								SPM	mm	mm
SSA16ALR	70	90	125	50	20	406	16	550-1600	414x254	0-45°	133x3x0.5	1650-4800	675x330x400	11.8 / 13	335	690	720

SSA16BLRF



New Scroll Saw With Foot Switch  
带脚踏开关的台式曲线锯

406 mm

50

125 W

Quick blade tension handle  
锯条涨紧把手

Flexible LED working light  
可灵活转动的LED工作灯

Safety cover  
安全护罩

Variable speed control  
切割速度可调

Cast AL large working table adjustable angle  
角度可调的铝压铸大工作台

Flexible dust blower  
万向鼓风机

Foot switch, free your hand when cutting  
脚踏开关, 在切割时解放双手

PTO shaft with 3.2 mm chuck accept different kits  
带3.2毫米的软轴, 可连接各种附件使用

Additional dust port  
外接排尘口

Optional cast AL work table with Miter Gauge  
可选带分度盘的铝压铸工作台



Technical Data/技术参数

Model 型号	WATT			Max cutting depth 最大切割厚度	Max cutting size 最大切割半径	Speed 速度范围	Table size 工作台尺寸	Table tilt 工作角度	Blade size 锯条尺寸	Flexible shaft speed/ 软轴速度	Carton size 包装尺寸	N.W. / G.W. 净重/毛重	Container load 装箱数
	Watts S1	Watts S2 30min	Watts S2 5min										
SSA16BLRF	70	90	125	mm at 0° mm at 45°	mm inch	SPM	mm mm	°	mm	RPM	mm	kg	20 GP/40 GP/40 HP
					406 16	550-1600	414x254	0-45°	133x3x0.5	1650-4800	675x330x400	12.0 / 13.5	335 690 720

VS4005A



406 mm

50

125 W



Blade quick changing system  
锯条快速更换系统



Variable Speed Design  
无极调速设计



Handle on frame for easy movement  
带提手, 方便移动



16" SCROLL SAW WITH HANDLE

- Flexible LED lamp
- Cast iron base, low vibration
- 405mm cutting capacity
- Blade quick changing system
- Variable speed control for cutting wood and plastic
- In-built dust blower
- Table adjustable 0-45°
- Pinless blade holder
- 弯管LED灯
- 铸铁底座, 低振动
- 切割板材直径度405mm
- 锯条快速更换系统
- 切割速度可调节用于切割木材或塑料
- 带鼓风机
- 工作台角度可调
- 可使用无销锯条

Technical Data/技术参数

Model 型号	WATT			Max cutting depth 最大切割厚度	Max cutting size 最大切割半径	Speed 速度范围	Table size 工作台尺寸	Table tilt 工作角度	Blade size 锯条尺寸	Flexible shaft speed/ 软轴速度	Carton size 包装尺寸	N.W. / G.W. 净重/毛重	Container load 装箱数
	Watts S1	Watts S2 30min	Watts S2 5min										
VS4005A	70	90	125	mm at 0° mm at 45°	mm inch	SPM	mm mm	°	mm	RPM	mm	kg	20 GP/40 GP/40 HP
					406 16	550-1600	414x254	0-45°	133x3x0.5	N/A	675x330x410	12.0 / 13.5	335 690 720



SSA18VL



456 mm

50 mm



120 W



Variable speed design  
无极调速设计

Cast iron work table low vibration  
低振动的铸铁工作台

Table adjustable -10°-45°  
工作台角度可调节

18" SCROLL SAW WITH LIGHT

- Flexible lamp
- Cast iron base ,low vibration
- 456mm cutting capacity
- Variable speed control for cutting wood and plastic
- In-built dust blower
- Table adjustable 0-45°
- Pinless blade holder

- 弯管灯
- 铸铁底座，低振动
- 切割板材直径度456m m
- 切割速度可调用于切割木材或塑料
- 带鼓风机
- 工作台角度可调
- 可使用无销锯条

Technical Data/技术参数

Model/ 型号	WATT		Max cutting depth		Max cutting size		Speed	Table size	Table tilt	Blade size	Flexible shaft	Carton size	N.W. / G.W.	Container load		
	Power	功率	mm at 0°	mm at 45°	mm	inch	速度范围	工作台尺寸	工作角度	锯条尺寸	软管长度	包装尺寸	净重/毛重	20 GP	40 GP	40 HP
	Watts S1	Watts S2 10min	mm	mm	mm	inch	SPM	mm	°	mm	RPM	mm	kg			
SSA18VL	70	120	50	20	456	18	550-1600	262X490	-10-45°	133x3x0.5	N/A	785x380x385	17.0 / 19.5	270	540	540

SSA18LVR



456 mm

50 mm



120 W



FLEXIBLE SHAFT  
软轴



18" SCROLL SAW WITH PTO SHAFT

- Flexible lamp
- Cast iron base ,low vibration
- 456mm cutting capacity
- Variable speed control for cutting wood and plastic
- In-built dust blower
- Table adjustable 0-45°
- Pinless blade holder
- 弯管灯
- 铸铁底座，低振动
- 切割板材直径度456m m
- 切割速度可调用于切割木材或塑料
- 带鼓风机
- 工作台角度可调
- 可使用无销锯条



Technical Data/技术参数

Model/ 型号	WATT		Max cutting depth		Max cutting size		Speed	Table size	Table tilt	Blade size	Flexible shaft	Carton size	N.W. / G.W.	Container load		
	Power	功率	mm at 0°	mm at 45°	mm	inch	速度范围	工作台尺寸	工作角度	锯条尺寸	软管长度	包装尺寸	净重/毛重	20 GP	40 GP	40 HP
	Watts S1	Watts S2	mm	mm	mm	inch	SPM	mm	°	mm	RPM	mm	kg			
SSA18LVR	70	120 (S2 10min)	50	20	456	18	550-1600	262X490	-10-45°	133x3x0.5	1650-4800	785x380x385	17.5 / 20.0	270	540	540

BS0802



203 mm

80 mm

BS0902



228 mm

89 mm



Dust Brush  
尘刷



Optional iron work table  
可选铁板工作台



Blade tension quick adjustment  
锯条快速涨紧

Adjustable LED light  
可调LED灯

Cast AL table(0-45°) with  
miter gauge  
带分度盘的铝压铸工作台

### Technical Data / 技术参数

Model / 型号	BS0802	BS0902
Motor S1 / 马达功率 S1	250 W	250 W
Motor Speed / 马达速度	1400 min <sup>-1</sup>	1400 min <sup>-1</sup>
Table Size / 工作台尺寸	300x300 mm / 313x302 mm	300x300 mm / 313x302 mm
Table Tilt / 工作台倾斜角度	0-45°	0-45°
Table Extension / 工作台延伸	No	No
Table Material / 工作台材质	Sheet metal or Aluminum	Sheet metal or Aluminum
Cutting Capacity / 喉深	203 mm	228 mm
Max. Cutting Height / 最大切割高度	80 mm	89 mm
Blade Size / 锯条尺寸	1400x6.35x0.35 mm 6TPI	1511x6.5x0.35 mm 6TPI
Optional Blade width / 可选锯条宽度	3.5-12 mm	3.5-12 mm
Blade Speed 50Hz / 锯条转速 50Hz	960 m/min	630 m/min
Blade Speed 60Hz / 锯条转速 60Hz	1152 m/min	760 m/min
Dust Port / 排尘口尺寸	28 mm	63.5 mm
Work Light / 工作灯	Optional	Optional
Rip Fence / 靠尺	Optional	Optional
Blade Guides / 轴承锯条导向	Pins	Pins + Bearing
Quick-Release Blade Tension / 快速锯条涨紧	No	Optional
Miter Gauge Included / 分度盘	Optional	Optional
Band Saw Stand / 支架	No	No
Package Size / 包装尺寸	715*395*315 mm	790*450*300 mm
Net./Gross Weight / 毛净重	17 / 18.3 kg	18.5 / 20.5 kg
Container Load 20GP / 装柜数	329	245
Container Load 40GP / 装柜数	651	504
Container Load 40HP / 装柜数	744	576

### 8" / 9" BAND SAW

- 250W induction motor
- Cast aluminum table 0~45°
- Quick blade tension
- Optional LED light
- Optional rip fence and miter gauge
- 250W 感应电机
- 铝压铸工作台 0~45° 调节
- 快速锯条涨紧
- 可选LED灯
- 可选靠尺和分度盘

BS1001



240 mm

100 mm

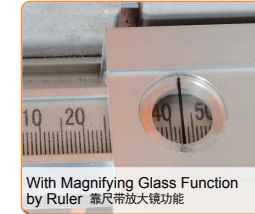

With Magnifying Glass Function  
by Ruler 靠尺带放大镜功能



Cast iron table  
铸铁工作台

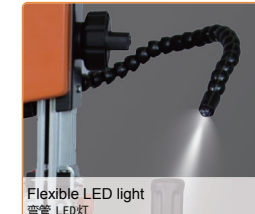

Flexible LED light  
弯管 LED灯

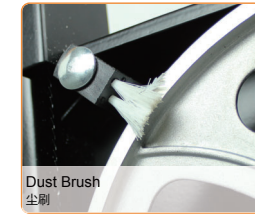

Dust Brush  
尘刷



### Technical Data / 技术参数

Model / 型号	BS1001 single speed	BS1003 double speed	BS1004 single speed	BS1005 double speed
Motor S1 / 马达功率 S1	370 W	600 W	600 W	600 W
Motor Speed / 马达速度	1400 min <sup>-1</sup>	1400 min <sup>-1</sup>	1400 min <sup>-1</sup>	1400 min <sup>-1</sup>
Table Size / 工作台尺寸	313x302 mm	335x340 mm	335x340 mm	335x340 mm
Table Tilt / 工作台倾斜角度	0-45°	0-45°	0-45°	0-45°
Table Extension / 工作台延伸	No	Yes	Yes	Yes
Table Material / 工作台材质	Aluminum	Cast iron	Cast iron	Cast iron
Cutting Capacity / 喉深	240 mm	240 mm	240 mm	240 mm
Max. Cutting Height / 最大切割高度	100 mm	100 mm	100 mm	100 mm
Blade Size / 锯条尺寸	1712x9.5x0.35mm 6TPI	1712x9.5x0.35mm 6TPI	1712x9.5x0.35mm 6TPI	1712x9.5x0.35mm 6TPI
Optional Blade width / 可选锯条宽度	3.5-12 mm	3.5-12 mm	3.5-12 mm	3.5-12 mm
Blade Speed 50Hz / 锯条转速 50Hz	730 m/min / 730, 950 m/min	730 m/min / 730, 950 m/min	730 m/min / 730, 950 m/min	730 m/min / 730, 950 m/min
Blade Speed 60Hz / 锯条转速 60Hz	870 m/min / 870, 1140 m/min	870 m/min / 870, 1140 m/min	870 m/min / 870, 1140 m/min	870 m/min / 870, 1140 m/min
Dust Port / 排尘口尺寸	99 mm, 62 mm, 47 mm	99 mm, 62 mm, 47 mm	99 mm, 62 mm, 47 mm	99 mm, 62 mm, 47 mm
Work Light / 工作灯	Optional	Optional	Optional	Optional
Rip Fence / 靠尺	Yes	Yes	Yes	Yes
Blade Guides / 轴承锯条导向	Three Bearings	Three Bearings	Three Bearings	Three Bearings
Quick-Release Blade Tension / 快速锯条涨紧	Yes	Yes	Yes	Yes
Miter Gauge Included / 分度盘	Yes	Yes	Yes	Yes
Band Saw Stand / 支架	Yes	Yes	Yes	Yes
Package Size / 包装尺寸	880*390*490 mm	880*390*490 mm	880*390*490 mm	880*390*490 mm
Net./Gross Weight / 毛净重	36.0 / 39.0 kg	37 / 40 kg	37 / 40 kg	37 / 40 kg
Container Load 20GP / 装柜数	152	152	152	152
Container Load 40GP / 装柜数	292	292	292	292
Container Load 40HP / 装柜数	395	395	395	395

### 10" BAND SAW

- Sturdy cast AL table tilting from 0° to 45° (optional cast iron)
- 3-bearing precision guiding above and below the table
- Balanced band wheels with rubber facing
- Working table extension
- Blade tension indication
- LED work light (optional)
- Quick door open system (no CE)
- 坚固的铝压铸工作台，0-45度可调 (可选铸铁工作台)
- 3轴承导向的锯轮，上下都是
- 平衡过的锯轮，胶圈经过磨床加工，运作平顺
- 工作台可延伸
- LED灯 (可选)
- 快速开门装置 (no CE)

BS1201



305 mm

206 mm



Unique vario drive. Adjustable speeds from 370 to 750 m/min.  
独特的无极调速设计



Sturdy cast-iron table tiltable from -8° to +45°  
坚固的铸铁工作台 -8° 到 +45° 调节

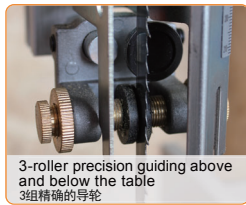

3-roller precision guiding above and below the table  
3组精确的导轮

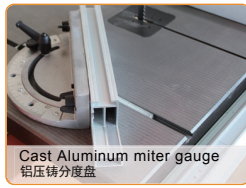

Cast Aluminum miter gauge  
铝压铸分度盘



12" BAND SAW

- Unique variable drive adjustable
- Sturdy cast-iron table tiltable from -8° to +45°
- 3-roller precision guiding above and below the table
- Balanced and grinded band wheels with rubber facing
- Quick-clamping lever for saw blade
- Precision rip fence with magnified scale which can be set on both left and right of saw blade
- Leg stand with wheel kit included
- 无级调速设计
- 坚固的铸铁工作台，可以从-8度调整到45度
- 上下都有3组精确的导轮
- 锯轮经过动平衡和磨床加工
- 快速锯条涨紧
- 精确的带放大镜的靠棚可以在锯条左面或右面使用
- 包括支架腿和轮子

BS1501

375 mm

250 mm

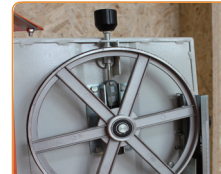

Two speeds for the most varying materials  
适合大部分材料的双速设计



Sturdy cast-iron table tiltable from -17° to +45°  
坚固的铸铁工作台 -17° 到 +45° 调节



3-roller precision guiding above and below the table  
3组精确的导轮

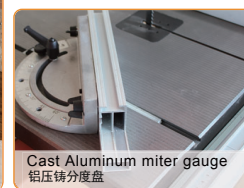

Cast Aluminum miter gauge  
铝压铸分度盘



15" BAND SAW

- 2 speed design
- Sturdy cast-iron table tiltable from -17° to +45°
- 3-roller precision guiding above and below the table
- Balanced and grinded band wheels with rubber facing
- Quick-clamping lever for saw blade
- Precision rip fence with magnified scale which can be set both on the left and right of saw blade
- Leg stand with wheel kit included
- 双速设计
- 坚固的铸铁工作台，可以从-17度调整到45度
- 上下都有3组精确的导轮
- 锯轮经过动平衡和磨床加工
- 快速锯条涨紧
- 精确的带放大镜的靠棚可以在锯条左面或右面使用
- 包括支架腿和轮子

Technical Data/技术参数

Model / 型号	BS1200	BS1201
Motor S1 / 马达功率 S1	800 W	800 W
Motor Speed / 马达速度	1400 min <sup>-1</sup>	1400 min <sup>-1</sup>
Table Size / 工作台尺寸	548x400 mm	548x400 mm
Table Tilt / 工作台倾斜角度	0-45°	-8-45°
Table Extension / 工作台延伸	No	No
Table Material / 工作台材质	Cast Iron	Cast Iron
Cutting Capacity/Throat / 锯深	305 mm	305 mm
Max. Cutting Height / 最大切割高度	206 mm	206 mm
Blade Size / 锯条尺寸	2360x12.7x0.5 mm 4TPI	2360x12.7x0.5 mm 4TPI
Optional Blade width / 可选锯条宽度	3-16 mm	3-16 mm
Blade Speed 50Hz / 锯条转速 50Hz	370 m/min, 800 m/min	370 ~ 750 m/min
Blade Speed 60Hz / 锯条转速 60Hz	440 m/min, 960 m/min	440 ~ 900 m/min
Dust Port / 排尘口尺寸	95 mm	95 mm
Work Light / 工作灯	Optional	Optional
Rip Fence / 靠尺	Yes	Yes
Blade Guides / 轴承锯条导向	Three ball Bearings	Three ball Bearings
Quick-Release Blade Tension / 快速锯条涨紧	Yes	Yes
Miter Gauge Included / 分度盘	Yes	Yes
Band Saw Stand / 支架	Yes	Yes
Package Size / 包装尺寸	1150*620*430 mm	1150*620*430 mm
Net/Gross Weight / 毛净重	68.0 / 74.0 kg	80.0 / 86.0 kg
Container Load 20GP / 装柜数	90	90
Container Load 40GP / 装柜数	180	180
Container Load 40HP / 装柜数	214	214

Technical Data/技术参数

Model / 型号	BS1501
Motor S1 / 马达功率 S1	1500 W
Motor Speed / 马达速度	1400 min <sup>-1</sup>
Table Size / 工作台尺寸	548x400 mm
Table Tilt / 工作台倾斜角度	-17-45°
Table Extension / 工作台延伸	No
Table Material / 工作台材质	Cast Iron
Cutting Capacity/Throat / 锯深	375 mm
Max. Cutting Height / 最大切割高度	250 mm
Blade Size / 锯条尺寸	2895x12.7x0.6 mm 4TPI
Optional Blade width / 可选锯条宽度	6-25 mm
Blade Speed 50Hz / 锯条转速 50Hz	700/1000 m/min
Blade Speed 60Hz / 锯条转速 60Hz	980/1200 m/min
Dust Port / 排尘口尺寸	95 mm
Work Light / 工作灯	Optional
Rip Fence / 靠尺	Yes
Blade Guides / 轴承锯条导向	Three Ball Bearings
Quick-Release Blade Tension / 快速锯条涨紧	Yes
Miter Gauge Included / 分度盘	Yes
Band Saw Stand / 支架	Yes
Package Size / 包装尺寸	1390*710*470 mm
Net/Gross Weight / 毛净重	106 / 114 kg
Container Load 20GP / 装柜数	48
Container Load 40GP / 装柜数	96
Container Load 40HP / 装柜数	96

TS-315AE



TABLE LENGTH EXTENSION (STANDARD) 延伸工作台



Table length extension can be installed right side 延伸工作台可以安装到右侧



Optional retractable leg 可选伸缩腿结构



315mm TABLE SAW

Ideal for sawing solid timbers, boards and other wood-like materials in the workshop and at the construction sites. Their generous specification fulfills the need for ripping, cross cutting, angle and compound angle cuts. 适用于切割木方, 板材和其他类似木材的材料。可以在工作间和建筑工地使用。该台锯的参数可以满足纵切, 横切, 切斜角和复合角切割。

- Powerful 2800 watts (2000 watt – 230 V) induction motor
- Long Life TCT blade – 315 mm
- Sturdy, powder-coated sheet steel design and galvanized table-top
- Table length extension (could be used also as table width extension)
- Suction guard with suction hose
- Height adjustment of saw blade continuously adjustable by a hand wheel
- 2 handles and wheels for easy transport
- Sturdy parallel guide/ripping fence
- Optional free assembly retractable legs for easy handling and storage
- 强劲的2.0kw-2.8kw的感应马达
- 长寿命的315毫米TCT锯片
- 牢固的, 喷粉钣金设计和镀锌工作台
- 带延伸工作台(也可以用作侧面辅助工作台)
- 吸尘护罩和吸尘管
- 锯片高度可以连续使用手轮调节
- 2个把手和脚轮方便搬运
- 牢固的导向规和靠山
- 可选免组装伸缩腿设计便于搬运和存放

Technical Data/技术参数

Model /型号	TS-315AE
Motor /马达功率	230V/50Hz, S6 40% 2000W 400V/50Hz, S6 40% 2800W
Motor Speed /马达速度	2800 RPM
Saw blade size /锯片尺寸	315x30x3.0 mm
Table Size /工作台尺寸	800x550 mm
Table Height /工作台高度	850 mm
Extension table size /延伸工作台尺寸	800x400 mm
Cutting tilting range /切割角度	0-45°
Cutting depth at 90° /切割深度	83 cm
Cutting depth at 45° /切割深度	49 cm
Sliding table adjustable /滑台角度	N/A
Sliding table guide rail /滑轨导轨	N/A
Package Size /包装尺寸	890x610x460 mm
Net./Gross Weight /毛净重	230V: 44 / 50 kg
Net./Gross Weight /毛净重	400V: 47 / 52 kg
Container Load 20GP /装箱数	110
Container Load 40GP /装箱数	225
Container Load 40HP /装箱数	225

TS-315BE



Table length extension (Standard) 延伸工作台

Sliding table extension (Standard) 滑台



315mm TABLE SAW

- Sliding table carriage standard
- Powerful 2800 watts (2000 watt – 230 V) induction motor
- Long Life TCT blade – 315 mm
- Sturdy, powder-coated sheet steel design and galvanized table-top
- Table length extension (could be used also as table width extension)
- Suction guard with suction hose
- Height adjustment of saw blade continuously adjustable by a hand wheel
- 2 handles and wheels for easy transport
- Sturdy parallel guide/ripping fence
- 标配滑动工作台
- 强劲的2.0kw-2.8kw的感应马达
- 长寿命的315毫米TCT锯片
- 牢固的, 喷粉钣金设计和镀锌工作台
- 带延伸工作台(也可以用作侧面辅助工作台)
- 吸尘护罩和吸尘管
- 锯片高度可以连续使用手轮调节
- 2个把手和脚轮方便搬运
- 牢固的导向规和靠山

Technical Data/技术参数

Model /型号	TS-315BE
Motor /马达功率	230V/50Hz, S6 40% 2000W 400V/50Hz, S6 40% 2800W
Motor Speed /马达速度	2800 RPM
Saw blade size /锯片尺寸	315x30x3.0 mm
Table Size /工作台尺寸	800x550 mm
Table Height /工作台高度	850 mm
Extension table size /延伸工作台尺寸	800x400 mm
Cutting tilting range /切割角度	0-45°
Cutting depth at 90° /切割深度	83 cm
Cutting depth at 45° /切割深度	49 cm
Sliding table adjustable /滑台角度	0-45°
Sliding table guide rail /滑轨导轨	960
Package Size /包装尺寸	890x610x460 mm
Net./Gross Weight /毛净重	230V: 53 / 58 kg
Net./Gross Weight /毛净重	400V: 55 / 61 kg
Container Load 20GP /装箱数	110
Container Load 40GP /装箱数	225
Container Load 40HP /装箱数	225

TS-315DE



Table length extension (Standard) 延伸工作台

Table length extension (Standard) 延伸工作台



Sliding table extension (Standard) 滑台

Technical Data/技术参数

Model/型号	TS-315DE
Motor /马达功率	230V/50Hz, S6 40% 2000W 400V/50Hz, S6 40% 2800W
Motor Speed/马达速度	2800 RPM
Saw blade size /锯片尺寸	315x30x3.0mm
Table Size /工作台尺寸	800x560 mm
Table Height /工作台高度	850 mm
Extension table size /延伸工作台尺寸	800x400 mm
Cutting tilting range /切割角度	0-45°
Cutting depth at 90° /切割深度	83 cm
Cutting depth at 45° /切割深度	49 cm
Sliding table adjustable /滑台角度	0-45°
Sliding table guide rail /滑轨导轨	960
Package Size /包装尺寸	890x610x460 mm
Net/Gross Weight /毛净重	230V: 57 / 63 kg
Net/Gross Weight /毛净重	400V: 60 / 65 kg
Container Load 20GP /装柜数	110
Container Load 40GP /装柜数	225
Container Load 40HP /装柜数	225

315mm TABLE SAW

- Sliding table carriage and side table standard
- Powerful 2800 watts (2000 watt – 230 V) induction motor
- Long Life TCT blade – 315 mm
- Sturdy, powder-coated sheet steel design and galvanized table-top
- Table length extension (could also be used as table width extension)
- Suction guard with suction hose
- Height adjustment of saw blade continuously adjustable by a hand wheel
- 2 handles and wheels for easy transport
- Sturdy parallel guide/ripping fence
- 标配滑动工作台和侧面辅助工作台
- 强劲的2.0kw – 2.8kw 的感应马达
- 长寿命的315毫米TCT 锯片
- 牢固的, 喷粉钣金设计和镀锌工作台
- 带延伸工作台 (也可以用作侧面辅助工作台)
- 吸尘护罩和吸尘管
- 锯片高度可以连续使用手轮调节
- 2个把手和脚轮方便搬运
- 牢靠的导向规和靠棚

TS-450



Table length extension (Standard) 延伸工作台

Approved BG pendulum saw guard (Standard) BG摆锤设计锯片护罩

TS-500A



Sliding table extension (Standard) 滑台



Foldable legs 折叠腿



Technical Data/技术参数

Model 型号	TS-500A	TS-450
Motor 马达功率	400V/50Hz S6 40% 4200W	230V/50Hz S6 40% 3200W
Motor Speed 马达速度	2800 RPM	2800 RPM
Saw blade size 直径/内孔/刀片宽度/刀片厚度/齿形/齿数	ø500/30x4/0.2.8mm WZ Z44	ø450/30/3.5/2.5mm WZ Z36
Table Size 工作台尺寸	1000x660 mm	1000x660 mm
Table Height 工作台高度	850 mm	850 mm
Extension table size 延伸工作台尺寸	800x400 mm	800x400 mm
Cutting tilting range 切割角度	90°	90°
Cutting depth at 90° 切割深度	150 cm	125cm
Cutting depth at 45° 切割深度	NA	NA
Sliding Miter Table 分度滑台	NA	NA
Sliding table guide rail 滑轨导轨	YES	YES
Dust Collection Port Dia 集尘口	100 mm	100 mm
Package Size 包装尺寸	1300x840x610 mm	1300x840x610 mm
Net/Gross Weight 毛净重	400V: 103 / 115 kg	400V: 103 / 115 kg
Container Load 20GP 装柜数	33	33
Container Load 40GP 装柜数	69	69
Container Load 40HP 装柜数	92	92

450/ 500mm Table Saw With Foldable Legs

- Foldable legs for easy handling and storage.
- Sliding table carriage and side table standard
- There is an approved BG pendulum saw guard that protects the user, adhering to the highest safety
- Powerful 4200 watts induction motor
- Long Life TCT blade – 500 mm
- Sturdy, powder-coated sheet steel design and galvanized table-top
- Table length extension (could also be used as table width extension)
- Suction guard with suction hose
- Height adjustment of saw blade continuously adjustable by a hand wheel
- 2 handles and wheels for easy transport
- Sturdy parallel guide/ripping fence
- 折叠腿方便搬运和储藏
- 标配滑动工作台和侧面辅助工作台
- BG 摆锤设计的锯片护罩最大程度保护使用者的安全
- 强劲的4200W 的感应马达
- 长寿命的500毫米TCT 锯片
- 牢固的, 喷粉钣金设计和镀锌工作台
- 带延伸工作台 (也可以用作侧面辅助工作台)
- 吸尘护罩和吸尘管
- 锯片高度可以连续使用手轮调节
- 2个把手和脚轮方便搬运
- 牢靠的导向规和靠棚

PT200A / PT250A



◀ 204 mm ▶

120

◀ 252 mm ▶

120



Angle adjustable fence(0-45°)  
角度可调的挡料板

8"/10" PLANER THICKNESSER

- Combination bench top jointer and planer provides a 2in1 machine to maximize work space.
- Powerful 2HP motor provides various cutting applications.
- Two high speed steel knives for precise, smooth cuts.
- Precision adjustment knobs.
- 组合式平刨和压刨，2合一的产品，节省工作空间
- 强力的2马力电机，可满足多种切割要求
- 两个高速钢刀片提供精确和平滑的切面
- 刨削高度可调

Technical Data/技术参数

	Model /型号	PT200A	PT250A
Specification 规格	Motor / 马达功率	1500 W	1500 W
	Dimensions / 机器尺寸	753x494x460 mm	954x494x483mm
	Cutter block speed / 刨刀转速	9000RPM	9000RPM
	No. of Blades / 刀片数量	2pcs	2pcs
Surface Planning 平刨	Surfacing table size / 上工作台尺寸	740x210 mm	920x263mm
	Plane width max / 最大刨削宽度	204 mm	252mm
	Stock removal max / 最大刨削深度	2.5 mm	2.5 mm
Thickening 压刨	Thickening table size / 下工作台尺寸	270x204 mm	270x303mm
	Clearance height / 加工高度	5-120 mm	5-120 mm
	Clearance width / 加工宽度	204 mm	252 mm
	Stock removal max / 最大刨削深度	2 mm	2 mm
	Feed speed / 进料速度	4 m/min	4 m/min
Packaging Data 包装数据	Carton Size / 包装尺寸	860x435x470 mm	1015x430x510 mm
	Net/Gross weight / 毛净重	24.0 / 27.0 kg	27.0 / 31.0 kg
	Container Load 20GP/40GP 装柜数	160/320	116/244
	Container Load 40HP / 装柜数	419	305

VSM-50



◀ 50 mm ▶

0-40

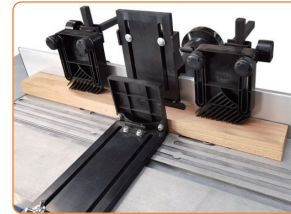

10" VERTICAL SPINDLE MOULDER

- Variable speed control 11500 to 24000 rpm
- Use router cutters shanks dia. 6/8/12mm
- Adjustable spindle height 0 to 40mm
- Motor power 2HP
- 2 x table width extensions as standard
- 转速可以在11500到24000RPM 调节
- 可使用6/8/12mm 的铣刀头
- 可调节的转轴高度从0到40mm
- 马达功率2马力
- 标配双延伸工作台

Technical Data/技术参数

Model /型号	VSM-50
Motor / 马达功率	1500 W
Dimensions / 机器尺寸	1030x360x311 mm
Table size / 工作台尺寸	610x360 mm
Extension single table size / 单个延伸工作台尺寸	210x360 mm
Speed / 转速	11500-24000 RPM
Router Cutters Shanks Dia. / 铣刀杆径	6/8/12 mm
Max Cutter Block diameter / 最大铣刀直径	50 mm
Spindle Height / 主轴升降高度	0-40 mm
Table Inserts / 盖板规格	32/47/55 mm
Carton Size / 包装尺寸	670x535x390 mm
Net/Gross Weight / 毛净重	21 / 23 kg
Container Load 20GP / 装柜数	192
Container Load 40GP / 装柜数	408
Container Load 40HP / 装柜数	408

# DUST COLLECTOR-PORTABLE 便携式集尘器

DC-D



183 m<sup>3</sup>/h  
1200 W  
50L



## Portable Dust Collector With Universal Motor 手提式串激电机集尘器

Excellent For The Small Workshop 适合小工作间使用

- Maximum efficiency with 0.5 micron rating.
- Flexible hose (100 mm) with multiple adaptors making ideal for use with singlepurpose machines such as a table saw and equally suitable for all power tools.
- Strong barrel container.
- 最大0.5微米的过滤能力。
- 配套100mm 的吸尘管和多种变径接口可以配套台锯等多种电动工具使用。
- 强壮的桶式机身

### Technical Data/技术参数

Category 类别	Model 型号	Motor Power (input)	Fan Diameter 风扇直径	Air Flow 风量		Air Pressure 风压	Bag Size 集尘袋容积	Bag Type 集尘袋规格	Hose size 吸尘管尺寸	Carton size 包装尺寸	N.W. / G.W. 净重/毛重		Container load 装箱数		
		Watts	mm	m <sup>3</sup> /h	CFM	in.H2O	L	micron	inch	mm	kg	20 GP	40 GP	40 HP	
				50Hz	60Hz										
Portable	DC-D	1200	130	183	108	10	50 (Drum)	2	4	420x420x720	10.5 / 12.0	210	420	476	

# DUST COLLECTOR-PORTABLE 便携式集尘器

DC30B



750 W  
88L

## Portable design 便携式设计

- TEFC motor
- 2 micron dust bag
- Hose support and handle
- High quality hose
- 风冷式封闭电机
- 2 微米的集尘袋
- 带软管支持杆和提手
- 高品质软管



Wall mounted  
悬挂状态



DC30A



750 W  
63L

## Economic model 经济款

- Casters
- TEFC motor
- 2 micron dust bag
- 带轮子
- 风冷式封闭电机
- 2 微米的集尘袋



### Technical Data/技术参数

Category 类别	Model 型号	Motor Power (input)	Motor Power (output)	Fan Diameter 风扇直径	Air Flow 风量		Air Pressure 风压	Bag Size 集尘袋容积	Bag Type 集尘袋规格	Hose size 吸尘管尺寸	Carton size 包装尺寸	N.W. / G.W. 净重/毛重		Container load 装箱数		
		Watts	Watts	mm	CFM		in.H2O	cu.ft	micron	inch	mm	kg	20 GP	40 GP	40 HP	
					50Hz	60Hz										
Portable	DC30B	750	550	228	450	550	5.8	3.1	2	4	530x430x565	20.0 / 22.0	228	460	541	
	DC30A	750	550	236	220	260	7	2.23	2	4	465x400x420	22.0 / 25.0	340	720	860	

# DUST COLLECTOR-MOVEABLE 移动式除尘器

DC-F



900 m³/h  
550 W  
65L



- Flexible 2 meter collection hose with 100mm inlet collects large volumes of chips and dust debris
- Easy replacement Large capacity dust bag
- Carry handle allows the unit to be easily moved around the work area when required
- 2米的大尺寸100毫米软管可以方便的清理灰尘和碎屑
- 方便更换的大容量集尘袋
- 把手可以方便的把集尘器移动到需要的地方

## Technical Data/技术参数

Category 类别	Model 型号	Motor Power (input) Watts	Fan Diameter 风扇直径 mm	Max Air Flow 最大风量		Air Pressure 风压 in.H2O	Bag Size 集尘袋容积 L	Bag Type 集尘袋规格 micron	Hose size 集尘管尺寸 inch	Carton size 包装尺寸 mm	N.W. / G.W. 净重/毛重 kg	Container load 装箱数		
				m³/h 50Hz	CFM 60Hz							20 GP	40 GP	40 HP
Mobile	DC-F	550	294	900	650	9.4	65	5	4	880x470x435	22.0 / 25.0	150	325	390

# DUST COLLECTOR-MOVEABLE 移动式除尘器

DC50



900 W  
140L



1.2HP

- Powerful TEFC motor
- 大功率风冷式封闭电机

## Technical Data/技术参数

Category 类别	Model 型号	Motor Power (input) Watts	Motor Power (output) Watts	Fan Diameter 风扇直径 mm	Air Flow 风量		Air Pressure 风压 in.H2O	Bag Size 集尘袋容积 cu.ft	Bag Type 集尘袋规格 micron	Hose size 集尘管尺寸 inch	Carton size 包装尺寸 mm	N.W. / G.W. 净重/毛重 kg	Container load 装箱数		
					CFM 50Hz	CFM 60Hz							20 GP	40 GP	40 HP
Mobile	DC50	900	750	254	500	660	8.5	4.93	30	4	750x460x485	36.5 / 38.0	156	312	390
	DC28	1500	1200	291	917	1100	6.6	11.8	30	4	900x485x450	45.5 / 47.0	150	305	305

DC28



1500 W  
334L



2HP

- Movable design
- 可移动式设计



# DUST COLLECTOR-TWO STAGES 集尘器

DC31 DC17  
DC18 DC21



Balanced blower  
风机

5 Micron filter bag  
5 微米的过滤袋

Metal drum 集尘桶



- Advantage of two stage dust collection
- Coarse and fine wood dust auto separate
- No coarse wood hitting blower impeller, which lead to unbalance and reduce impeller's life
- Filter bag Easy clean and long life

- 二级集尘器的优势
- 自动分离大的木屑和粉尘
- 大的木屑无法进入风腔，风扇的精度和寿命得到提高
- 过滤袋容易清洁，使用寿命更长

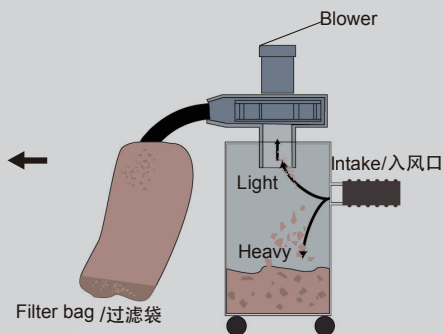

## Technical Data/技术参数

Category 类别	Model 型号	Motor Power		Fan Diameter 风扇直径	Air Flow 风量		Air Pressure 风压	Bag Size 集尘袋容积	Bag Type 集尘袋规格	Drum 集尘桶	Hose size 集尘管尺寸	Carton size 包装尺寸		N.W. / G.W 净重/毛重			Container load 装箱数		
		Watts	Watts		CFM							mm	kg	20 GP			40 GP		
					50Hz	60Hz						in.H2O	cu.ft	micron	inch	mm			
2 Stage	DC31	750	550	254	500	600	7.1	4.2	5	DC32	4	675x550x470	24.0 / 26.0	95	190	230			
	DC17	1500	1200	305	917	1100	7.3	6.5	5	DC33	5	745x640x495	36.0 / 38.0	60	120	140			
	DC18	1500	1200	305	917	1100	7.3	6.5	5	DC33	5	745x640x495	36.0 / 38.0	60	120	140			
	DC21	2000	1500	330	1092	1310	9	6.5	5	DC33	6	745x640x495	37.0 / 40.0	60	120	140			
Drum	DC32	Metal drum 24 Gallon / 0.11 cu.meter			11升的金属桶			550x550x355		10.0 / 13.0		N/A		N/A		N/A			
	DC33	Metal drum 55 Gallon / 0.25 cu.meter			25升的金属桶			670x670x530		16.0 / 19.0		N/A		N/A		N/A			

# CENTRAL CYCLONE DUST COLLECTOR 中央旋风集尘器

DC24  
DC25  
DC26  
DC29



Class F Insulation Tefc Motor For Continuous Duty  
连续工作的F级绝缘的全封闭马达

Cyclone System  
旋风吸尘系统

55 Gallon Steel Drum  
55 加仑的铁集尘桶

3~



## Central Cyclonic dust collectors- One equipment for whole work shop 中央旋风集尘器- 一台设备供全车间使用

- Cyclonic dust collector can separate the heavy dust particles from the fine particles and drop them into the 55 gallon steel drum, it's easier to clean.
- 旋风集尘器可以将大颗粒碎屑从粉尘中剥离，沉降到铁桶中，清理更容易。

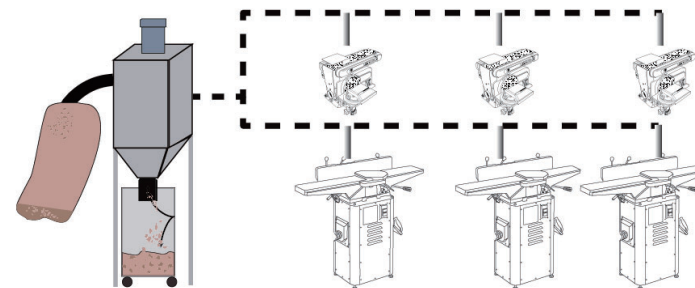

## Technical Data/技术参数

Category 类别	Model 型号	Motor Power		Fan Diameter 风扇直径	Air Flow 风量		Air Pressure 风压	Bag Size 集尘袋容积	Bag Type 集尘袋规格	Drum 集尘桶	Hose size 集尘管尺寸	Carton size 包装尺寸		N.W. / G.W 净重/毛重			Container load 装箱数		
		Watts	Watts		CFM							mm	kg	20 GP			40 GP		
					50Hz	60Hz						in.H2O	cu.ft	micron	inch	mm	kg		
2 Stage	DC24	5000	3750	368	2167	2600	12	23.3	5	DC33*2	7	1175x760x630	167 / 172	27	55	60			
	DC25	5000	3750	368	2167	2600	12	23.3	5	DC33*2	7	1175x760x630	161 / 166	27	55	60			
	DC26	7580	5625	381	2417	2900	13	37.4	5	DC33*4	7	1550x1220x860	219 / 313	8	18	25			
	DC29	9350	7500	394	2667	3200	14	37.4	5	DC33*4	7	1550x1220x860	312 / 332	8	18	25			
Drum	DC33	Metal drum 55 Gallon / 0.25 cu.meter			25升的金属桶			670x670x530		19.0 / 20.2		N/A		N/A		N/A			

DC20  
DC22  
DC23



3~

Spark Free Design / 防火花设计



Balanced aluminum fan  
动态平衡过的铝扇叶

Stable glass fiber reinforced plastics frame  
高强度玻纤风腔



Handle for easy moving  
方便搬运的手

- Fume/smoke exhauster primarily used for removing fumes and smoke that are generated from processes like sanding, melting, welding, heating and painting.
- 排烟机可以将抛磨, 融化, 焊接, 加热过程中产生的烟雾排出工作区域.

- FEATURES: 机器特性:
- Moveable 移动方便
  - Sturdy construction 结构牢固
  - Durable 经久耐用
  - Low maintenance 低维护成本

- APPLICATION AREA: 应用领域:
- Foundries 铸造
  - Rubber industry 橡胶
  - Glass industry 玻璃
  - Steel painting 钢铁喷漆
  - Wooden furniture 实木家具

Technical Data/技术参数

Category 类别	Model 型号	Motor Power (input)	Motor Power (output)	Fan Diameter 风扇直径	Air Flow 风量		Air Pressure 风压	Hose size 集尘管尺寸	Carton size 包装尺寸	N.W. / G.W. 净重/毛重	Container load 装箱数		
		Watts	Watts		CFM						20 GP	40 GP	40 HP
					50Hz	60Hz					in.H2O	inch	mm
Fume/Smoke Exhauster	DC20	750	550	254	500	600	7	4	490x430x575	19.0 / 20.0	252	504	516
	DC22	1500	1200	305	917	1100	5.6	5	580x560x690	35.0 / 38.0	120	249	252
	DC23	1500	1200	305	917	1100	5.6	5	580x560x690	35.0 / 38.0	120	249	252

HSG2000



1-1/2" Diameter cutting capacities  
38mm 最大切割直径



Manganese steel V blade for fast leaves shredding  
锰钢立刀快速粉碎树叶



Technical Data/技术参数

Model /型号	HSG2000		
Motor /马达功率	1500 W		
Motor speed /马达转速	50Hz	2850RPM	
	60Hz	3450RPM	
Cutting capacities /粉碎能力	38mm		
Hopper size /进料口尺寸	395*265 mm		
Gross Weight /毛重	32.5kg		
Carton Size /包装尺寸	780*480*380		
Container Load 20GP /装箱数	210 pcs		



COMPOSTING

MULCHING

CHIPPING

SHREDDING

- Quieter and cleaner than gas-powered machines
- The powerful induction electric motor produces 1700w peak power for quick work of small branches and tree limbs up to 38mm.
- The 3-way feed, shredding and mulching system ensures consistent, quality results with all types of yards debris.
- 电动花园碎枝机比汽油式要干净和安静
- 大马力感应电机在粉碎树枝和树叶时,可以达到1700瓦的峰值功率
- 3种进料方式, 撕裂和粉碎系统能保证花园碎枝被充分的处理

## CM350



**LDPE drum**  
低密度聚乙烯桶

**Molded In Blades Increase Mixing Efficiency**  
桶身自带搅拌齿 提高搅拌效率

**TEFC Induction motor**  
全封闭钢壳电机

**Rigid steel frame**  
牢固的钢管支架



### Technical Data/技术参数

Model /型号	CM350	
Motor /马达功率	370 W	
Motor speed /马达转速	50Hz	26 RPM
Motor speed /马达转速	60Hz	31 RPM
Capacities /搅拌能力	50 L	
Drum Size /桶容积	80 L	
Gross Weight /毛重	54.5 kg	
Carton Size /包装尺寸	780x480x380 mm	
Container Load 20GP /装柜数	81 pcs	

**Never Rust! Easy Clean! Multi-function Mixing for Animal Food & Agricultural Seeds.** 永不生锈! 易清洗! 适用于搅拌饲料, 种子.

## Wheel Barrow Concrete Mixer 手推车式混凝土搅拌机

### RM80

**Weight Balance Design Easy Feed Out**  
重量经过平衡设计 倒出方便

**TEFC Induction motor**  
全封闭钢壳电机

**Rigid steel frame**  
牢固的钢管支架



### Technical Data/技术参数

Model /型号	RM80	
Motor /马达功率	500 W	
Motor speed /马达转速	50Hz	26 RPM
Motor speed /马达转速	60Hz	31 RPM
Capacities /搅拌能力	80 L	
Drum Size /桶容积	130L	
Gross Weight /毛重	69 kg	
Carton Size /包装尺寸	594x580x765 mm	
Container Load 20GP /装柜数	115 pcs	

## Grey Grinding Wheel

No.	Description		Which Machine used for	Optimal wheel hole Size
	wheel size	wheel optional grit		
01	75*13*10	3*1/2*3/8	Bench Grinder	NA
02	125*16*12.7	5*5/8*1/2		20mm or 32mm
03	150*20*12.7	6*3/4*1/2		20mm or 32mm
04	150*25*12.7	6*1*1/2		20mm or 32mm
05	175*25*12.7	7*1*5/8		20mm or 32mm
06	200*20*15.88	8*3/4*5/8		36#,60#,80#,
07	200*25*15.88	8*1*5/8		100#,120#,
08	250*25*20	10*1*3/4		180#,240#
09	300*50*32	12*2*1-1/4		36#,60#
				NA



## White Grinding Wheel

No.	Description		Which Machine used for
	wheel size	wheel optional grit	
01	150*40*12.7	6*1-1/2*1/2	Bench Grinder
02	200*25*15.88	8*1*5/8	
03	200*40*15.88	8*1-1/2*5/8	



## Wire Brush Wheel

No.	Description		Which Machine used for
	wheel size		
01	MM	Inch	Bench Grinder
02	150*13.5*12	6*17/32*1/2	
	200*16*15.88	8*5/8*5/8	

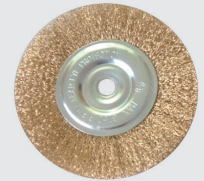

## Wet Grinding Wheel

No.	Description		Which Machine used for
	wet wheel size	wheel optional grit	
01	118*38*14	4-1/2*1-1/2 *9/16	SCM4500
02	200*25*12.7	8*1*1/2	SCM5800
03	200*40*20	8*1-1/2*3/4	TDS-150EWG/TLG-150WG
04	200*40*12	8*1-1/2*1/2	SCM8080
05	250*50*12	8*2*1/2	SCM8101



## Dry Grinding Wheel

No.	Description		Which Machine used for
	dry wheel size	wheel optional grit	
01	MM	Inch	SCM5800
	125*50*12.7	5*2*1/2	
		120#	



## Buffing Wheel

No.	Description		Which Machine used for
	wheel size		
	MM	Inch	
01	75*17*10	3*5/8*3/8	Buffing Machine
02	150*8*12.7	6*5/16*1/2	
03	200*10*15.88	8*3/8*5/8	
04	250*20*20	10*3/4*3/4	



## Sanding Belt

No.	Description		Which Machine used for
	belt size		
	MM	Inch	
01	25.4*762	1*30	Bench Grinder Sander
02	25.4*1067	1*42	
03	50*686	2*27	
04	50*710	2*28	
05	51*1067	2*42	
06	51*1220	2*48	
07	100*914	4*36	
08	100*1220	4*48	
09	150*1220	6*48	



## Sanding Disc Paper

No.	Description		Which Machine used for
	disc size		
	MM	Inch	
01	125	5	Bench Grinder Sander
02	150	6	
03	200	8	
04	229	9	
05	250	10	
06	305	12	



## Band Saw Blade

No.	Description		Which Machine used for
	size (mm)		
01	1400*6.35*0.35	6TPI	Band Saw
02	1511*6.5*0.35	6TPI	
03	1712*9.5*0.35	6TPI	
04	2360*12.7*0.5	4TPI	
05	2895*12.7*0.6	4TPI	



Name.	Which Machine used for	Which Machine used for	
	All Machine	Star Dressing Tool	Diamond Dressing Tool
	Magnetic Base Light		
			

## Saw Blade

No.	Description		Which Machine used for	Country of Origin	
	Length*Width*Thickness				
	MM	Inch			
01	133*3*0.5	5*2*1/2	Scroll Saw	Made in China	
02	133*2.4*0.25	5*0.095*0.01			Made in Spain
03	133*2.8*0.5	5*0.11*0.02			Made in Spain



## Spiral Saw Blade

No.	Description		Which Machine used for	Country of Origin
	Length*Width*Thickness			
	MM	Inch		
01	130*1.25(Dia.)	5*0.039(Dia.)	Scroll Saw	Made in Spain
02	130*1.45(Dia.)	5*0.046(Dia.)		Made in Spain

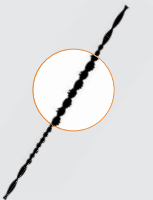

## Geometry Saw Blade

No.	Description		Which Machine used for	Country of Origin
	Length*Width*Thickness			
	MM	Inch		
01	130*1.7*0.52	5*0.67*0.02	Scroll Saw	Made in Spain
		TPI:7/6; CMS:3/2.5		

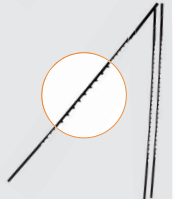

## Table saw Blade

No.	Description		Which Machine used for
	saw blade size	teeth	
01	315*30*3.0/1.8	24,48	Table Saw
02	500*30*4/2.8	44	

