

# ALLWIN 奥文

## PRODUCT CATALOGUE



授权经销:  
AUTHORIZED DEALER:



## ALLWIN 奥文 2019

文登奥文电机有限公司 (原文登市电机厂)  
WENDING ALLWIN MOTORS MANUFACTURING CO.,LTD.  
(former: Wending Electrical Machinery Factory)

地址: 中国·山东省威海市文登经济开发区昆桥北路196号  
Add: No. 196 Kunyu North Road, Wending Economic development zone, Weihai City, Shandong, China

四产路分公司: 山东省威海市文登经济开发区四产路15-1号  
Power tool Branch office Add: No. 15-1 Sichan Road, Wending Economic development Zone, Weihai City, Shandong, China 264400

Tel: +86-631-846 0181

Fax: +86-631-845 1624

marketing@allwin-motor.com



www.allwin-motor.com



No.196 Kunyu North Road,  
Wendeng Economic Development  
Zone  
Weihai city , Shandong , China  
山东省威海市文登经济开发区昆崙北  
路196号

Power tool Branch Office  
No.15-1 Sichan Road, Wendeng  
Economic Development Zone ,Weihai  
City , Shandong , China  
电动工具分厂, 山东省威海市文登经济发  
展区四产路15-1号



**Wendeng Allwin Motors Manufacturing Co., Ltd.**  
文登奥文电机有限公司

### LOGN HISTORY

Established in 1955; Motor production since 1978; Power tools business start from 1989;

### CAPACITY

Key manufacturer and exporter of bench top power tools in China. 960 employ-  
ess located in 3 factorys with total land size of 240,000sqm, 50 engineers and  
100 QC staffs.

Averagely 20+ x 20FCL containers delivered each week.

### PROFESSIONAL

Nearly 20 years OEM business practice since 1999 serving 30 top retailers.



## CONTENTS

## 目录

### BENCH GRINDER 砂轮机



Page: 1-16

### SHARPENER 磨刀机



Page: 17-19

### BENCH GRINDER SANDER 砂轮砂带机



Page: 20-22

### BUFFING MACHINE 抛光机



Page: 23-24

### SANDING MACHINE 砂光机



Page: 25-31

### FLOOR CARE 地板修理



Page: 32

### BENCH GRINDER STAND 砂轮机支架



Page: 33

### DRILL PRESS 台钻



Page: 34-40

### SCROLL SAW 台式曲线锯



Page: 41-47

### BAND SAW 带锯



Page: 48-51

### TABLE SAW 台锯



Page: 52-55

### PLANNER THICKNESSER 平压刨



Page: 56

### Vertical Spindle Moulder 铣床



Page: 57

### COMBINED WOODWORKING MACHINE 木工组合机



Page: 58

### DUST COLLECTOR 集尘器



Page: 59-63

### FUME/SMOKE EXHAUSTER 排烟机



Page: 64

### GARDEN SHREDDER 花园碎枝机



Page: 65

### CONCRETE MIXER 水泥搅拌机



Page: 66

### ACCESSORY 附件



Page: 67

# TDS LINE BENCH GRINDER TDS系列砂轮机

Bench Grinder  $\phi$  150mm/6 inch  
**TDS-150EBL2**

Adjustable Eyeshield and Spark Deflector  
可调节的护目镜和火花挡板

150 mm  
400 W

CE  
C SP US

Steel Base (Optional Cast iron and Cast AL base)  
钢板底座 (可选铸铁和铝压铸材质)



**6" LED LIGHTED BENCH GRINDER**

LED Light powered by battery  
电池供电LED灯  
Angle adjustable LED light illuminates the work space, promoting accurate sharpening.

Protective Eye Guards  
护镜阻止火花和碎屑  
Eye guards provide vital protection from spark and debris for safe operation.

## TDS LINE BENCH GRINDER / TDS系列砂轮机特点

### TECHNICAL FEATURES AND STANDARD FITTINGS

#### CLASSIC LINE OF BENCH GRINDER

- Reliable and silent induction motors with ball bearing
- Accept both wire wheel and grinding wheel
- Equipped with adjustable work rest and safety glass
- Targeted for hobby to professionals
- Three phase available for 8 and 10 inch
- Lamp available for all line

#### 经典砂轮机系列

- 可靠, 安静的感应马达
- 可安装标准砂轮片以及钢丝轮
- 标配活动托架, 护目镜
- 可满足从爱好者到专业人士的不同需要
- 200以及250毫米砂轮机可选三相机
- 所有TDS系列砂轮机可选配灯



Brush Wheel Optional  
可选钢丝轮

# TDS LINE BENCH GRINDER TDS系列砂轮机

Bench Grinder  $\phi$  125mm/5 inch  
**TDS-125A**

Bench Grinder  $\phi$  150mm/6 inch  
**TDS-150EE**

CE

Bench Grinder  $\phi$  150mm/6 inch  
**TDS-150EB**

C SP US CE

180 W

250 W

TDS-125A  
TDS-150EA  
Cast Iron Base  
铸铁底座

TDS-125B  
TDS-150EB  
Steel base  
钢板底座

TDS-125C  
TDS-150EC  
Cast AL base  
铝压铸底座

- Adjustable work rest and spark deflector
- Optional magnifier shield for precision grinding
- 可调节的托架以及火花挡板
- 选配的放大镜可以更精确的观察工件

- Adjustable work rest and spark deflector
- Optional magnifier shield for precision grinding
- 可调节的托架以及火花挡板
- 选配的放大镜可以更精确的观察工件

Bench Grinder  $\phi$  150mm/6 inch  
**TDS-150EBL**

Bench Grinder  $\phi$  200mm/8 inch  
**TDS-200CL**

C SP US

250 W

370 W

550 W

- 3 Times Magnifier shield / 3倍放大护目镜
- Industrial lamp with E27 Bulb Holder / 工业款灯罩, 使用E27灯口
- Patent Rigid steel base, stable / 专利牢固, 轻便的钢板底座 and light weight

- Optional quick wheel guard release / 可选快速拆卸护罩
- Coolant tray / 冷却水槽
- Magnifier shield / 放大护目镜
- Cast Aluminum base / 铝压铸底座
- Industrial light / 工业款灯罩

### Technical Data/技术参数

Model/型号	WATT		Wheel size/砂轮尺寸		Wheel grit/砂轮粒度	Motor speed/马达转速		Carton size/包装尺寸	NW/GW 净重/毛重	Container load/装箱数		
	Watts (S1)	Watts (S2 30min)	MM	Inch		50Hz	60Hz			MM	KG	20 GP
TDS-125A	120W	180W	125*16*12.7	5*5/8*1/2	36# / 60#	2980	3580	300*190*265	6.0 / 6.5	1928	3784	4830
TDS-125B			125*16*12.7	5*5/8*1/2	36# / 60#	2980	3580	345*240*245	5.5 / 6.5	1485	2889	3320
TDS-125C	CE 180W	CE 250W	125*16*12.7	5*5/8*1/2	36# / 60#	2980	3580	345*240*245	5.5 / 6.5	1485	2889	3320
TDS-150EE			150*20*12.7	6*3/4*1/2	36# / 60#	2980	3580	345*240*245	7.5 / 8.5	1485	2889	3320
TDS-150EA	250	370	150*20*12.7	6*3/4*1/2	36# / 60#	2980	3580	405*295*270	7.0 / 8.2	912	1800	2061
TDS-150EB	180	250	150*20*12.7	6*3/4*1/2	36# / 60#	2980	3580	345*240*245	6.5 / 7.6	1485	2889	3320
TDS-150EC	180	250	150*20*12.7	6*3/4*1/2	36# / 60#	2980	3580	345*240*245	6.5 / 7.6	1485	2889	3320
TDS-150EBL	180	250	150*20*12.7	6*3/4*1/2	36# / 60#	2980	3580	460*240*240	7.3 / 8.3	1098	2205	2739
TDS-150EBL2	250	400 S2 10min	150*20*12.7	6*3/4*1/2	36# / 60#	2980	3580	395*255*245	8.0 / 9.2	1224	2403	2690
TDS-150CL	250	370	150*20*12.7	6*3/4*1/2	36# / 60#	2980	3580	490*285*250	8.0 / 9.3	882	1728	1950
TDS-200CL	370	550	200*25*15.88	8*1*5/8	36# / 60#	2980	3580	530*325*305	14.0 / 15.3	539	1085	1240

# TDS LINE BENCH GRINDER

# TDS系列砂轮机

# TDS LINE BENCH GRINDER

# TDS系列砂轮机

Bench Grinder  $\phi$  150mm/6 inch  
Bench Grinder  $\phi$  200mm/8 inch  
**TDS-150 / TDS-200**

**370 W**  
**550 W**

• Cast Iron Motor Housing Bench Grinder / 铸铁马达壳  
• Cast iron base / 铸铁底座

Bench Grinder  $\phi$  175mm/7 inch  
**TDS-175C**

**375 W**

Coolant Tray  
冷却水槽

• Quick wheel guard release / 快速拆卸护罩  
• Cast AL base / 铝压铸底座  
• Tool less adjustable eyeshield and work rest / 不需要工具的附件调节

Bench Grinder  $\phi$  200mm/8 inch  
**TDS-200EA**  
Bench Grinder  $\phi$  200mm/8 inch  
**TDS-200EB**

**370 W**  
**550 W**

• Cast iron base  
• Adjustable work rest and spark deflector  
• 铸铁底座  
• 可调节的托架以及火花挡板

Bench Grinder  $\phi$  200mm/8 inch  
**TDS-200H**  
Bench Grinder  $\phi$  250mm/10 inch  
**TDS-250E**

**750 W**  
1~ 3~

• Cast iron motor housing  
• Cast iron base  
• 750W motor available  
• 铸铁马达壳  
• 铸铁底座  
• 可选最大750瓦特马达

## Technical Data/技术参数

Model/型号	WATT		$\phi$ mm		RPM		a x b x h mm		NW / GW 净重/毛重	Container load/装箱数		
	Power/功率		Wheel size/砂轮尺寸		Motor speed/马达转速		Carton size/包装尺寸			20 GP	40 GP	40 HP
	Watts (S1)	Watts (S2 30min)	MM	Inch	50Hz	60Hz	MM	Left / Right				
TDS-150	250	370	150*25*12.7	6"11/2"	36# / 60#	2980	3580	427*310*280	8.3 / 9.6	824	1616	1854
TDS-200	370	550	200*25*15.88	8"11/8"	36# / 60#	2980	3580	427*310*280	12.8 / 14.0	824	1616	1854
TDS-175C	250	375	175*25*15.88	7"11/8"	36# / 60#	2980	3580	430*330*310	12.2 / 13.5	672	1320	1520
TDS-200EA	250	370	200*25*15.88	8"11/8"	36# / 60#	2980	3580	420*375*290	14.5 / 16.0	888	1368	1566
TDS-200EB	370	550	200*25*15.88	8"11/8"	36# / 60#	2980	3580	420*375*290	15.0 / 16.8	888	1368	1566
TDS-200H	550	750	200*25*15.88	8"11/8"	36# / 60#	2980	3580	450*345*330	12.0 / 13.5	602	1204	1376
TDS-250E	550	750	250*25*20	10"13/4"	36# / 60#	2980	1790	450*345*330	21.0 / 23.0	602	1204	1376

Bench Grinder  $\phi$  200mm/8inch  
**TDS-200EBL2**  
**TDS-200EBL3**

**500 W**

Stable work rest, Tool-less Adjustable  
可靠的托架, 无需工具即可调节

3 Bulbs LED light with independent switch  
带独立开关的3头LED灯

Two kinds of grindstone, a coarse grey grinding wheel and 40 mm wide WA grinding wheel for low temperature sharpening  
带两种磨石, 棕刚玉砂轮片和40mm宽白刚玉砂轮片对工件进行低温磨削

Optional cast iron base  
可选铸铁底座

- Powerful 500W motor delivers smooth, accurate results
- Eye shields protect you from flying debris without obstructing your view
- Inbuilt LED worklights over wheels keep work piece lit
- Cast-AL base with pre-drilled holes for quick and easy mounting to a benchtop
- Adjustable tool rests extend the life of the grinding wheels
- Rubber feet for increased stability
- 配套强大的500瓦电机, 带来平顺和精确的打磨效果
- 护目镜能够保护你远离火花, 不会影响视线
- 内置的LED灯, 可以照亮工件
- 带有2个固定孔的铝压铸底座, 可以方便的固定在台面上
- 托架可以跟随砂轮片调节, 延长砂轮片的使用寿命
- 橡胶底脚增加了机器的稳定性

## Technical Data/技术参数

Model/型号	WATT		$\phi$ mm		RPM		a x b x h mm		NW / GW 净重/毛重	Container load/装箱数		
	Power/功率		Wheel size/砂轮尺寸		Motor speed/马达转速		Carton size/包装尺寸			20 GP	40 GP	40 HP
	Watts (S1)	Watts (S2 30min)	MM	Inch	50Hz	60Hz	MM	Left / Right				
TDS-200EBL2	370	500 S2 10min	200*20*15.88	8"3/4"5/8"	36# / 60#	2980	3580	425*320*310	11.5 / 13.0	632	1302	1450
TDS-200EBL3	370	500 S2 10min	200*20*15.88 200*40*15.88	8"3/4"5/8" 8"1-3/5"5/8"	60# / 100#	2980	3580	440*320*310	13.5 / 15.0	725	1442	1662
TDS-250	550	750	250*25*20	10"13/4"	36# / 60#	2980	1790	520*395*365	30.0 / 32.0	378	750	875
TDS-250H	750	900	250*25*20	10"13/4"	36# / 60#	2980	1790	520*395*365	29.5 / 31.5	378	750	875
TDS-250D4	800	1000	250*25*20	10"13/4"	36# / 60#	2980	1790	520*395*365	31.0 / 33.0	378	750	875

# TDS LINE BENCH GRINDER TDS系列砂轮机

Bench Grinder  $\phi$  250mm/10inch  
**TDS-250**

**10" INDUSTRIAL BENCH GRINDER**  
10寸工业款砂轮机



**750 W**



**Optional Work Stand**  
可选配支架

- Heavy duty motor
- Cast iron motor housing
- Cast iron base
- Forward wheel guard minimizes the spattering sparks

- 重型马达设计
- 铸铁马达壳
- 铸铁底座
- 前突的护罩使飞溅的火花减少到最小

Bench Grinder  $\phi$  250mm/10inch  
**TDS-250D4**



Bench Grinder  $\phi$  250mm/10inch  
**TDS-250H**

**1000 W**

**900 W**

1~

3~



**Cast Aluminum work rest**  
铝压铸工作台

**Safety switch with key**  
带钥匙的安全开关

- Heavy duty motor
- Cast iron motor housing
- Cast iron base
- Forward wheel guard minimize the fly of sparks

- 重型马达设计
- 铸铁马达壳
- 铸铁底座
- 前突的护罩使飞溅的火花减少到最小

# HBG LINE BENCH GRINDER HBG系列砂轮机

Bench Grinder  $\phi$  150mm/6 inch  
**HBG620A**

**250 W**



**HBG LINE BENCH GRINDER**  
HBG系列砂轮机特点

- Streamlined double shield induction motor design  
流线型双层壳感应马达
- Accept both wire wheel and grinding wheel  
可安装标准砂轮片以及钢丝轮
- Equipped with adjustable work rest and safety glass  
标配活动托架, 护目镜
- Targeted for hobby to professionals  
可满足从爱好者到专业人士的不同需要
- Three phase available for 8 and 10 inch 200 以及250毫米砂轮机可选三相电机

**10w Flexible working light**  
可灵活转动的10瓦白炽灯  
**Optional LED light(1 Watt)**  
可选LED灯(1瓦)



Bench Grinder  $\phi$  150mm/6 inch  
**HBG625L**



**370 W**



**Wheel Dresser**

砂轮修整器  
For cleaning and reshaping the grinding wheel between uses.  
Stored on clip on the top of grinder when not in use.

- 10w Flexible working light
- 3 Times Magnifier Shield
- Quick wheel guard release
- Includes water cooling tray and hand held wheel dresser
- Streamlined Double shield motor Low surface temperature
- 可灵活转动的10瓦白炽灯
- 3倍放大护目镜
- 护罩快速拆卸功能
- 内置冷却水槽和手持砂轮修整器
- 低表面温度的流线型双层马达壳设计

Bench Grinder with brush wheel  $\phi$  150mm/6 inch  
**HBG620B**



**250 W**



**Can be used for:**

Rust removal, cleaning of metal and non-ferrous metal, preparation of soldering and welding work.

- Flexible working light
- 3 Times Magnifier Shield
- Quick wheel guard release
- Includes water cooling tray and hand held wheel dresser
- Streamlined Double shield motor Low surface temperature
- 可灵活转动的工作灯
- 3倍放大护目镜
- 护罩快速拆卸功能
- 内置冷却水槽和手持砂轮修整器
- 低表面温度的流线型双层马达壳设计

# HBG LINE BENCH GRINDER

# HBG系列砂轮机

# TLG LINE BENCH GRINDER

# TLG系列砂轮机

Bench Grinder  $\phi$  200mm/8 inch

**HBG818L**  
**HBG825L**



**370 W**  
**550 W**



- Cast aluminum Base
- Flexible working light
- 3 Times Magnifier Shield
- Quick wheel guard release
- Includes water cooling tray and hand held wheel dresser
- 铝压铸底座
- 可灵活转动的工作灯
- 3倍放大护目镜
- 护罩快速拆卸功能
- 内置冷却水槽和手持砂轮修整器

Bench Grinder  $\phi$  250mm/10 inch

**HBG1025L**

**750 W**



- Cast Iron Base
- 3 Times Magnifier Shield
- Optional flexible working light
- In-Built water cooling tray
- 铸铁底座
- 3倍放大护目镜
- 可灵活转动的工作灯 (可选)
- 内置水槽

Bench Grinder  $\phi$  200mm/8 inch

**HBG825HL**

Bench Grinder  $\phi$  150mm/6 inch

**HBG620HA**



**550 W**   **250 W**

- Cast Aluminum Base
- Flexible working light
- 3 Times Magnifier Shield
- Angle adjustable work rest
- Includes water cooling tray and hand held wheel dresser
- Include 40mm width WA grinding wheel for low temperature sharpening
- 铝压铸底座
- 可灵活转动的工作灯
- 3倍放大护目镜
- 角度可调节的工作台
- 内置冷却水槽和手持砂轮修整器
- 带一片40mm厚度的白刚玉砂轮片



40mm width WA grinding wheel for low temperature sharpening  
40mm宽白刚玉砂轮片对工件进行低温磨削

## Technical Data/技术参数

Model/型号	WATT		$\phi$ mm		RPM	Carton size/包装尺寸 mm	NW / G.W 净重/毛重 KG	Container load/装柜数				
	Power/功率		Wheel size/砂轮尺寸					Motor speed/马达转速		20 GP	40 GP	40 HP
	Watts (S1)	Watts (S2 30min)	MM	Inch				50Hz	60Hz			
HBG620A	180	250	150*20*12.7	6*3/4*1/2	36# / 60#	2980	3580	425*255*290	9.3 / 10.0	984	1984	2232
HBG620B	180	250	150*20*12.7	6*3/4*1/2	36# (left)	2980	3580	425*255*290	9.1 / 9.8	984	1984	2232
			150*13.5*12	6*17/32*1/2	Brush wheel							
HBG625L	250	370	150*25*12.7	6*1*1/2	36# / 60#	2980	3580	440*255*290	10.0 / 11.0	960	1920	2196
HBG818L	250	370	200*20*15.88	8*3/4*5/8	36# / 60#	2980	3580	465*345*325	14.5 / 16.0	595	1127	1360
HBG825L	370	550	200*25*15.88	8*1*5/8	36# / 60#	2980	3580	480*345*325	15.0 / 16.5	560	1120	1200
HBG620HA	180	250	150*20*12.7	6*3/4*1/2	36#	2980	3580	425*255*290	9.8 / 10.5	984	1984	2232
			150*40*12.7	6*1-1/2*1/2	60#							
HBG825HL	370	550	200*25*15.88	8*1*5/8	60#	2980	3580	480*335*325	18.0 / 19.2	535	1070	1150
			200*40*15.88	8*1-1/2*5/8	100#							
HBG1025	550	750	250*25*20	10*1*3/4	36# / 60#	2980	3580	515*385*325	25.5 / 27.0	448	896	1088

Bench Grinder  $\phi$  150mm/6 inch

**TLG-150L2**

**250 W**



3 Times Magnifier  
3倍放大护镜

Angle adjustable work rest  
角度可调的托架

In-Built Coolant Tray  
内置冷却水槽



**PATENTED: Auto In-built Twin Light**  
专利点: 自动开启的内置双灯



**Magnifier shield**  
放大护目镜

- Coolant tray
- Heavy cast iron base
- Cast aluminum angle adjustable work rest
- Heavy cast iron base with rubber feet and 4 mounting holes
- 冷却水槽
- 重型铸铁底座
- 铝压铸工作台, 角度可调
- 重型的铸铁底座带有4个安装孔和橡胶脚

## TLG LINE BENCH GRINDER / TLG系列砂轮机特点

### TECHNICAL FEATURES AND STANDARD FITTINGS

- Auto lighted twin lamp
- Accept both wire wheel and grinding wheel
- Equipped with AI adjustable work rest and eye shield
- Targeted for hobby to professionals
- 自动开启的双灯
- 可安装标准砂轮片以及钢丝轮
- 标配角度可调的铝托架, 护目镜
- 可满足从爱好者到专业人士的不同需要

# TLG LINE BENCH GRINDER

# TLG系列砂轮机

Bench Grinder  $\phi$  200mm/8 inch  
**TLG-200L2**

**370 W**

- Coolant tray
- Auto-on twin light
- 3 Times Magnifier shield
- Heavy cast iron base
- Cast aluminum angle adjustable work rest
- 冷却水槽
- 自动开启的内置双灯
- 3倍放大护目镜
- 重型铸铁底座
- 铝压铸工作台，角度可调



Bench Grinder  $\phi$  200mm/8 inch  
**TLG-200L3**

**370 W**



- Auto-on twin light
- 3 Times Magnifier shield
- Cast iron base
- Cast aluminum angle adjustable work rest

Bench Grinder  $\phi$  200mm/8 inch  
**TLG-200L4**

**550 W**



- 自动开启的内置双灯
- 3倍放大护目镜
- 铸铁底座
- 铝压铸工作台，角度可调

## Technical Data/技术参数

Model/型号	WATT		$\phi$ mm		RPM		a x b x h mm			kg	Container load/装箱数				
	Power/功率		Wheel size/砂轮尺寸		Motor speed/马达转速		Carton size/包装尺寸				NW /GW 净重/毛重				
	Watts (S1)	Watts (S2 30min)	MM	Inch	50Hz	60Hz	MM	20 GP	40 GP		40 HP	KG	20 GP	40 GP	40 HP
TLG-150L2	180	250	150*20*12.7	6*3/4*1/2	36# / 60#	2980	3580	370*335*260	9.8 / 11.0	918	1890	2100			
TLG-200L2	250	370	200*25*15.88	8*1*5/8	36# / 60#	2980	3580	420*390*285	16.0 / 17.3	672	1200	1512			
TLG-200L3	250	370	200*25*15.88	8*1*5/8	36# / 60#	2980	3580	415*370*280	15.0 / 16.5	704	1368	1566			
TLG-200L4	370	550	200*25*15.88	8*1*5/8	36# / 60#	2980	3580	415*370*280	15.3 / 16.8	704	1368	1566			

# RBG LINE BENCH GRINDER

# RBG系列砂轮机

Bench Grinder  $\phi$  150mm/6 inch  
**RBG618A | RBG625A**



**250 W**  
**370 W**



Auto In-built Twin Light  
自动开启的内置双灯

## RBG LINE BENCH GRINDER RBG系列砂轮机特点

- Auto lighted twin lamp
- Accept both wire wheel and grinding wheel
- Equipped with angle adjustable magnify glass
- Targeted for hobby to professionals
- 自动开启的双灯
- 可安装标准砂轮片以及钢丝轮
- 标配带角度调节的放大镜
- 可满足从爱好者到专业人士的不同需要



Streamlined Double shield motor Low surface temperature  
低表面温度的流线型双层马达壳设计

Bench Grinder  $\phi$  200mm/8 inch  
**RBG818A**

**370 W**

- Auto-on twin light
- Coolant tray
- 3 Times Magnifier Shield
- Streamlined Double shield motor Low surface temperature
- 自动开启的内置双灯
- 冷却水槽
- 3倍放大护目镜
- 低表面温度的流线型双层马达壳设计

Bench Grinder  $\phi$  200mm/8 inch  
**RBG825A**

**550 W**



## Technical Data/技术参数

Model/型号	WATT		$\phi$ mm		RPM		a x b x h mm			kg	Container load/装箱数				
	Power/功率		Wheel size/砂轮尺寸		Motor speed/马达转速		Carton size/包装尺寸				NW /GW 净重/毛重				
	Watts (S1)	Watts (S2 30min)	MM	Inch	50Hz	60Hz	MM	20 GP	40 GP		40 HP	KG	20 GP	40 GP	40 HP
RBG618A	180	250	150*20*12.7	6*3/4*1/2	36# / 60#	2980	3580	400*345*250	9.5 / 10.2	880	1800	1940			
RBG625A	250	370	150*25*12.7	6*1*1/2	36# / 60#	2980	3580	400*345*250	10.3 / 11.0	880	1800	1940			
RBG818A	250	370	200*20*15.88	8*3/4*5/8	36# / 60#	2980	3580	435*395*315	15.7 / 16.9	545	1123	1160			
RBG825A	370	550	200*25*15.88	8*1*5/8	36# / 60#	2980	3580	435*395*315	16.3 / 17.5	545	1123	1160			

# PBG LINE BENCH GRINDER PBG系列砂轮机

# SPECIAL BENCH GRINDER 特种砂轮机系列



Bench Grinder  
φ125mm/5inch  
**PBG-125L2 / PBG-150L2**

Bench Grinder  
φ150mm/6inch

180 W

250 W

Angle adjustable LED light  
角度可调的LED灯

Handle 提手

WA grinding wheel  
(wire brush blade  
disc sharpen optional)  
钢丝磨轮/砂轮片 可选

Die-casting aluminum motor  
housing with handle  
铝压铸马达壳, 带提手

Large casting AL base,  
low vibration  
大的铝压铸底座, 减少震动

## NEW BENCH GRINDER WITH PORTABLE HANDLE 新款带提手砂轮机



Stable Work Rest,  
Tool-less adjustable

可靠的托架, 无需工具  
即可调节

Adjustable Eye-  
shield and spark  
deflector

可调节的火花挡板 and  
护目镜

In-built LED light

内置LED灯

Blade Disc Sharpen

磨锯刀架

Large casting AL  
base, low vibration

大的铝压铸底座, 减少  
震动



Bench Grinder  
φ250mm/10 inch  
**M3025**

Bench Grinder  
φ300mm/12 inch  
**M3030**

1100 W

1500 W

Forward wheel guard minimizes  
the fly of sparks  
前突的护罩使飞溅的火花减少到最小

Optional  
Work Stand  
可选支架

Can connect to dust  
collector  
可连接集尘器

## INDUSTRIAL LEVEL / 工业款重型砂轮机特点

- Heavy duty motor with continuous working capacity
- larger body ideal for industrial machining
- Super strong cast iron work rest
- NVR switch with anti-rest safety function and emergency stop
- 可持续工作的重型马达
- 宽大的机身设计, 可磨削大的工件
- 强壮的铸铁托架
- 可选带急停盖的电磁开关, 防止意外启动

### Technical Data/技术参数

Model/型号	WATT		φmm		RPM		a x b x h mm		NW / G.W 净重 / 毛重 KG	Container load/ 装箱数		
	Power/功率		Wheel size/砂轮尺寸		Motor speed/马达转速		Carton size/包装尺寸			20 GP	40 GP	40 HP
	Watts (S1)	Watts (S2 30min)	MM	Inch	50Hz	60Hz	MM	20 GP				
PBG-125L2	120	180	125*16*12.7	5"5/8"1/2	36# / 60#	2980	3580	365*250*280	6.5 / 7.5	1192	2304	2691
PBG-150L2	180	250	150*20*12.7	6"3/4"1/2	36# / 60#	2980	3580	365*250*280	7.5 / 8.5	1192	2304	2691

### Technical Data/技术参数

Model/型号	WATT		φmm		RPM		a x b x h mm		NW / G.W 净重 / 毛重 KG	Container load/ 装箱数		
	Power/功率		Wheel size/砂轮尺寸		Motor speed/马达转速		Carton size/包装尺寸			20 GP	40 GP	40 HP
	Watts (P1)	Watts (P2)	MM	Inch	50Hz	60Hz	MM	20 GP				
M3025	1100	750	250*32*32	10"1-1/4"1-1/4	36# / 60#	2980	1790	800*415*405 430*330*740 (Stand)	48.0 / 50.0 17.7 / 19.5	130	260	315
M3030	1500	900	300*40*75	12"1-1/4"3	36# / 60#	1490	1790	720*510*510 430*330*740 (Stand)	61.0 / 72.0 17.7 / 19.5	95	190	230



Professional Wood Worker Choice 木工专业之选

Bench Grinder  $\phi$  200mm/8inch  
TDS-200DS



300 W

DUAL SPEED WOODWORKER'S GRINDER 8IN. 8寸双速砂轮机

Two speed sharpen with different grinding wheel  
可使用不同的砂轮进行高速或低速打磨

- Angle adjustable work rest / 可旋转的托架
- Tool-less adjustment / 无需工具即可调节
- Inbuilt drill bits sharpen guide / 带钻头研磨导向
- Powerful two speed induction motor, quick startup, smooth performance and steady speeds at both low or high speed  
强大的双速感应马达, 启动迅速, 运行平稳, 高低速稳定。
- Includes 60 grit gray aluminum oxide wheel and 80 grit white aluminum oxide wheel  
包括一个60粒度的棕刚玉砂轮片和一个80粒度的白刚玉砂轮片
- Gray wheel at high speed is ideal for material removal and general purpose grinding  
棕刚玉砂轮片在高速时适用于金属去料和一般的打磨。
- White 80 grit wheel is ideal for sharpening operations because it can reduce heat build-up  
白色80粒度白刚玉砂轮适用于磨刀操作, 因为白刚玉可以减少热量的产生
- The slow speed is better for sharpening edges with a nice smooth finish when compared with faster RPM  
低速时更适合磨一些刀具的棱角, 相比高速打磨, 会得到更平滑的处理效果。

Powerful Two Speed Motor  
强劲的双速马达



Cast aluminum work rest  
铝压铸工作台

Main switch with two speed position  
双速调节的电源主开关

Cast iron base with Anti-vibration rubber feet  
带减震橡胶底角的铸铁底座

Technical Data/技术参数

Model/型号	WATT		$\phi$ mm		RPM	Motor speed/马达转速	Carton size/包装尺寸	N/W / G/W 净重/毛重	Container load/装柜数					
	Power/功率		Wheel size/砂轮尺寸						Wheel grit/砂轮粒度	50Hz	60Hz	20 GP	40 GP	40 HP
	Watts (S1)	Watts (S2 30min)	MM	Inch										
TDS-200C4	250	370	200*25*15.88	8"1"5/8	60# / 120#	1490	1790	480*375*290	15.5 / 17.0	592	1192	1341		
TDS-200D4	500	700	200*25*15.88	8"1"5/8	60# / 120#	1490	1790	620*400*370	24.5 / 26.5	312	636	742		
TDS-200DS	180	300	200*25*15.88	8"1"5/8	80# / 60#	1490/2980	1790/3580	415*370*285	15.5 / 17.0	704	1368	1566		

Professional Wood Worker Choice 木工专业之选

Bench Grinder  $\phi$  200mm/8inch  
TDS-200C4



370 W



8" LOW SPEED BENCH GRINDER  
8寸低速砂轮机

- Low speed motor
- High quality WA grinding wheel
- Angle adjustable work rest
- Safety switch with key
- 低速马达
- 高品质的白刚玉砂轮片
- 角度可调节的工作台
- 带安全锁开关

Bench Grinder  $\phi$  200mm/8inch  
TDS-200D4



700 W



3 Times Magnifier shield  
3倍放大护目镜



8" INDUSTRIAL BENCH GRINDER  
8寸工业款砂轮机

- High quality WA grinding wheel
- Cast iron Base with rubber feet
- Adjustable work rest and spark resistors
- 高品质的白刚玉砂轮片
- 铸铁底座带底脚
- 可调节的托架及火花挡板

KEEP IT COOL - Ideal for sharpening operations because it reduces heat build-up  
防止工件过热-白刚玉砂轮片可以在磨削时降低工件温度, 适合打磨作业

VARIABLE SPEED LINE BENCH GRINDER 调速系列砂轮机

Bench Grinder  $\phi$  150mm/200mm  
TLG-150VL / TLG-200VL

180 W 370 W

VS grinder can meet your requirement of different sharpen speed!  
调速砂轮机可满足对不同磨削速度的需求!



Cast Aluminum Adjustable Tool Rests  
铝压铸角度可调工作台

Two piece tool rests can be adjusted for wheel wear and accurate angles. Left side rest has pre-cast groove for drill bit sharpening.



Heavy cast iron base  
重型铸铁底座

Heavy duty base reduce vibration during operation and ensures safe mounting

- Variable speed motor
- Coolant tray
- 3 Times Magnifier shield
- Auto on twin light
- Cast aluminum angle adjustable work rest
- 无级调速马达
- 冷却水槽
- 3倍放大护目镜
- 自动开启的内置双灯
- 铝压铸的角度可调工作台

# VARIABLE SPEED LINE BENCH GRINDER 调速系列砂轮机

# CH LINE BENCH GRINDER CH系列砂轮机

Bench Grinder  $\phi$  150mm/200mm  
TDS-G150V/TDS-G200V



Bench Grinder  $\phi$  150mm/200mm  
TDS-G150VLDB/TDS-G200VLDB

300 W  
550 W



### Variable Speeds 调速设计

Convenient upfront located knob for speed ranges from 2000 to 3400 RPM. Provides control of speeds depending on the material being used.

- Variable speed motor
- Industrial lamp
- Coolant tray
- Heavy cast iron base
- Cast aluminum angle adjustable work rest

- 无级调速马达
- 工业款灯罩
- 冷却水槽
- 重型铸铁底座
- 铝压铸的角度可调工作台

### Technical Data/技术参数

Model/型号	WATT		$\phi$ mm		RPM		a x b x h (mm)	N.W./G.W. 净重/毛重	Container load/装箱数				
	Power/功率		Wheel size/砂轮尺寸		Motor speed/马达转速				MM	KG	20 GP	40 GP	40 HP
	Watts (S1)	Watts (S2 30min)	MM	Inch	50Hz	60Hz							
TLG-150VL	180	250	150*20*12.7	6*3/4*1/2	60# / 36#	2000-2976	2000-3450	385*345*260	12.5 / 13.5	918	1800	2040	
TLG-200VL	370	550	200*25*15.88	8*1*5/8	60# / 36#	2000-2976	2000-3450	420*410*285	18.0 / 19.5	560	1120	1260	
TDS-G150V	180	300	150*20*12.7	6*3/4*1/2	60# / 36#	2000-2976	2000-3450	515*325*265	13.7 / 14.8	640	1272	1620	
TDS-G200V	370	550	200*25*15.88	8*1*5/8	60# / 36#	2000-2976	2000-3450	540*340*295	17.7 / 19.2	444	900	1125	
TDS-G150VLDB	180	250	150*20*12.7 150*13.5*12.7	6*3/4*1/2 6*11/32*1/2	36# Brush	2000-2976	2000-3450	515*325*265	13.7 / 14.8	640	1272	1620	
TDS-G200VLDB	370	550	200*25*15.88 200*16*15.88	8*1*5/8 8*5/8*5/8	36# Brush	2000-2976	2000-3450	540*340*295	17.7 / 19.2	576	1168	1314	

250 W  
550 W



### Flexible Work Light 可灵活转动的工作灯

A flexible work light illuminates the work space, promoting accurate sharpening. 照明工作区域, 更精确打磨



- Variable speed motor
- Industrial lamp
- Coolant tray
- Right side wire wheel
- Heavy cast iron base
- Cast aluminum angle adjustable work rest

- 无级调速马达
- 工业款灯罩
- 冷却水槽
- 右侧钢丝轮
- 重型铸铁底座
- 铝压铸的角度可调工作台

Bench Grinder $\phi$ 150mm/6inch <b>CH150B-DC</b>	250 W
Bench Grinder $\phi$ 175mm/7inch <b>CH175</b>	370 W
Bench Grinder $\phi$ 200mm/8inch <b>CH200</b>	550 W
Bench Grinder $\phi$ 250mm/10inch <b>CH250</b>	750 W

### CH LINE BENCH GRINDER CH系列砂轮机特点

- Industrial standard bench grinder
- Equipped with a totally enclosed ball bearing motor.
- The armature assembly is dynamically balanced for smooth operation.
- The motor housing is compact so long pieces of work can pass against both wheels without touching the motor frame.
- In build dust collection hose can connect with dust hose
- The tool rests are adjustable for wheel wear and angle grinding.

- 工业级品质砂轮机
- 带球轴承的全封闭马达
- 转子经过动平衡, 保证平顺的操作性能
- 加长机身, 在磨长工件时不会被电机干扰
- 机身自带吸尘管可连接吸尘器
- 托架可调节前后和角度

Bench Grinder  $\phi$  300mm / 12inch  
**CH300**



1100 W



### Optional Work Stand 可选支架

### Technical Data/技术参数

Model/型号	WATT		$\phi$ mm		RPM		a x b x h (mm)	N.W./G.W. 净重/毛重	Container load/装箱数				
	Power/功率		Wheel size/砂轮尺寸		Motor speed/马达转速				MM	KG	20 GP	40 GP	40 HP
	Watts (S1)	Watts (S2 30min)	MM	Inch	50Hz	60Hz							
CH150A	150	250	150*20*12.7	6*3/4*1/2	36# / 60#	2980	3580	505*295*285	13.0 / 14.5	728	1424	1647	
CH150B	250	370	150*25*12.7	6*1*1/2	36# / 60#	2980	3580	505*295*285	14.0 / 15.0	728	1424	1647	
CH175	370	550	175*25*15.88	7*1*5/8	36# / 60#	2980	3580	595*395*410	22.3 / 24.0	270	535	642	
CH200	550	750	200*25*15.88	8*1*5/8	36# / 60#	2980	3580	595*395*410	27.5 / 29.5	270	535	642	
CH200T	550(400V)	750(400V)	200*25*15.88	8*1*5/8	36# / 60#	2980	3580	595*395*410	27.5 / 29.5	270	535	642	
CH250	550	1100	250*25*20	10*1*3/4	36# / 60#	2980	1790	700*470*450	43 / 46	160	300	415	
CH250T	450(400V)	900(400V)	250*25*20	10*1*3/4	36# / 60#	2980	1790	700*470*450	43 / 46	160	300	415	
CH300	900 (P2)	1500(P2)	300*50*32	12*2*1-1/4	36# / 60#	1490	1790	wooden box					

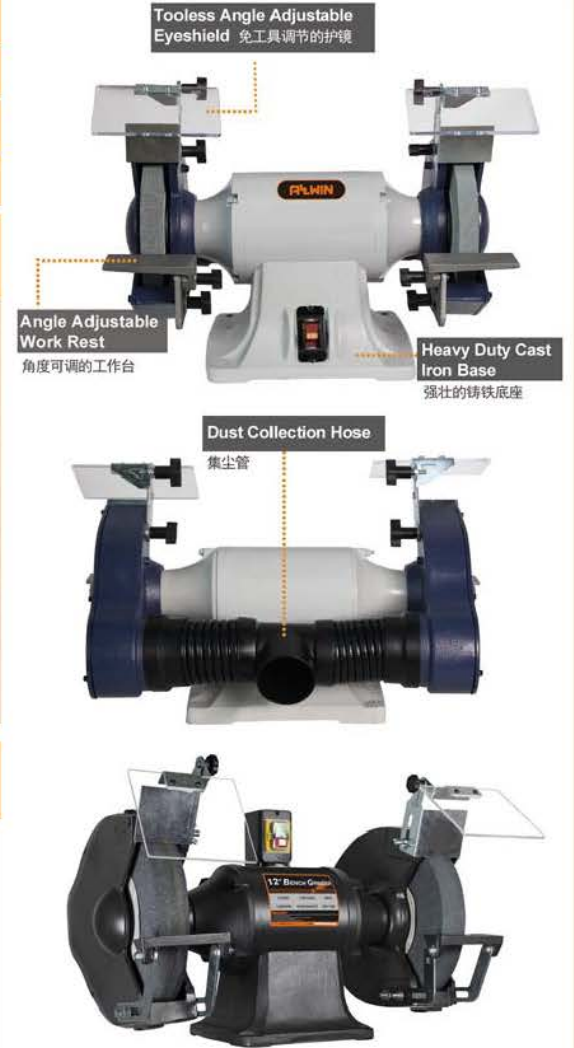

**TLG-150EWG** 

 **400 W**

Optional LED light  
可选LED灯

High speed dry grinding  
高速干磨

Low Speed Wet Sharpening  
低速湿磨

**6" WET/DRY GRINDER**

Dust proof switch  
防尘开关罩

Cast aluminum base  
铝压铸底座



## 8" x 6" Wet / Dry Grinder 干湿两用砂轮机

- Powerful induction motor delivers smooth, accurate results
- Eye shield protects you from flying debris without obstructing your view
- Coolant tray for cooling heated material
- Adjustable tool rests extend the life of the grinding wheels
- 200 mm wheel for wetstone application
- 动力充沛的感应马达保证了平顺和精确的磨削效果
- 护目镜保护你免受飞溅的伤害，不会影响视线
- 水槽可以冷却发热的工件
- 可调节的托架，延长砂轮片的使用寿命
- 200毫米的湿轮

**TLG-150WG**

 **250 W**





### Technical Data/技术参数

Model/型号	WATT		Dry wheel		Wet wheel		RPM		a x b x h mm		Container load / 装柜数				
	Power/功率		Dry wheel size/砂轮尺寸		Wet wheel size/砂轮尺寸		Motor speed / 马达转速		Carton size / 包装尺寸						
	Watts (S1)	Watts (S2 30min)	MM	Inch	MM	Inch	50Hz	60Hz	MM	KG					
TLG-150WG	180	250	150*20*12.7	6"3/4*1/2	60#	200*40*20	8"1-1/2*3/4	80#	2980/136	3580/162	485*330*365	12.8 / 13.5	480	1020	1176
TLG-150EWG	250	400 S2 10min	150*20*12.7	6"3/4*1/2	60#	200*40*20	8"1-1/2*3/4	80#	2980/136	3580/162	485*330*365	11.5 / 13	480	1020	1176

## 8" x 6" Wet / Dry Grinder 干湿两用砂轮机

**RBG-150WG**

 **250 W**

- Dust proof switch
- Magnify glass
- Coolant tray
- 防尘开关罩
- 放大镜
- 冷却水槽



## Special For Carbide Tool Finishing 硬质合金刀具专用

**TG-6L**

 **550 W**



- Green silicon carbide wheel / 绿碳化硅砂轮片
- Industrial light / 工业款灯罩
- Cast iron construction / 整机铸铁结构
- Angle adjustable cast iron table / 铸铁的角度可调工作台

## Low Speed Utility Blade Sharpener 低速多用磨刀机



**SCM4500**

 **80 W**



- Two Side Cast Al Work Rest / 砂轮两端均有铝工作台
- Two Sharpening Direction / 砂轮正反转动
- 120 Grit Wet / Dry sharpening stone / 120粒度干湿两用磨刀轮

## Universal Sharpening Center 通用磨刀机



**SCM5800**

 **370 W**



- High speed W A dry wheel
- Low speed wet wheel 400 #
- Height and angle adjustable cast iron work rest
- 高速白刚玉砂轮
- 400目低速湿轮
- 高度和角度可调的铸铁磨刀架

### Technical Data/技术参数

Model/型号	WATT		Dry wheel		Wet wheel		RPM		a x b x h mm		Container load / 装柜数				
	Power/功率		Dry wheel size/砂轮尺寸		Wet wheel size/砂轮尺寸		Motor speed / 马达转速		Carton size / 包装尺寸						
	Watts (S1)	Watts (S2 30min)	MM	Inch	MM	Inch	50Hz	60Hz	MM	KG					
RBG-150WG	180	250	150*20*12.7	6"3/4*1/2	60#	200*40*20	8"1-1/2*3/4	80#	2980/136	3580/162	505*335*360	11.6 / 12.3	438	912	1057
SCM5800	250	370	125*50*12.7	5"2*1/2	120#	200*25*12.7	8"1"1/2	400#	2980/335	3580/394	500*365*330	15.5 / 17	518	1070	1192
TG-6L	370	550	150*25*32	6"1"1-1/4	80#	150*25*32	6"1"1-1/4	80#	2980	3580	465*375*305	43.3 / 44	525	1057	1256
SCM4500	50Hz:70W 60Hz:80W	N/A	N/A	N/A	N/A	118*38*14	4-1/2"1-1/2*9/16	120#	146	176	395*235*195	4.5 / 5	1529	3168	3718

# SHARPENER 磨刀机系列

8" Universal Wet Sharpener  
通用款湿轮磨刀机

SCM8080

180 W

Polishing Wheel  
抛光轮



- Gear Transmission Supply More Sharpening Torque
- Universal Sharpening Jigs Support
- 220 Grit WA Grinding Wheel
- Leather Strapping Wheel
- 齿轮传动提供更锋利的扭矩
- 万能磨具支架
- 220粒度白刚玉砂轮片
- 毛皮轮

10" Low Speed Wet Sharpener  
低速湿轮磨刀机

SCM8101

180 W



## Technical Data/技术参数

Model/型号	WATT		Dry wheel		Wet wheel		RPM		a x b x h mm	NW/GW 净重/毛重	Container load / 盛柜数		
	Power/功率 Watts	HP	Dry wheel size/砂轮尺寸 grit/粒度		Wet wheel size/砂轮尺寸		Motor speed / 马达转速						
			MM	Inch	MM	Inch	50Hz	60Hz					
SCM8080	180	1/4	200*40*12	8"1-1/2*1/2	220#	200*30*12	8"1-1/5*1/2	95	115	380*365*345	10.5/11.8	576	1428
SCM8101	180	1/4	250*50*12	6"2*1/2	220#	200*30*12	8"1-1/5*1/2	95	115	390*375*355	15.3/16.5	576	1428

# BENCH GRINDER SANDER 砂轮砂带机系列

TLGS625

150 mm

370 W



**Sanding Belt Angle 0-90°**  
砂带可垂直或水平设置  
Tilt the belt from a horizontal to a vertical position or anywhere in between depending on the needs of your project.  
砂带可水平、垂直调整，或者在任何一个位置锁定，角度调节可依你的作业需求。



**Flexible Light**  
灵活转动的工作灯  
Flexible work light illuminates the work space, promoting accurate sanding.



**Dust Collection Port**  
集尘器接口  
The dust port clears dust from your work area.

**2x6" BENCH GRINDER SANDER**  
2x6" 砂轮砂带机

- Combination machine include both grinding wheel and sanding belt
- Eye shields protect you from flying debris without obstructing your view
- Adjustable tool rests extend the life of the grinding wheels
- Coolant tray for cooling heated material
- 组合式机器，同时拥有砂轮和砂带
- 护目镜保护你免受飞溅的伤害，不会影响视线
- 可调节的托架，延长砂轮片的使用时间
- 水槽可以冷却发热的工件

TDS-150CSL



150 mm

370 W

- Flexible light
- 3 Times Magnifier shield
- Quick belt release and easy tracking
- 可灵活转动的工作灯
- 3倍放大护目镜
- 砂带快速拆卸及调整



**Cast AL Base/  
Coolant Tray**  
铝压铸底座 / 水槽  
Water tray to help keep workpiece cool while grinding.  
打磨时冷却水槽可帮助工件冷却。



# BENCH GRINDER SANDER

# 砂轮砂带机系列

RBGS625

150 mm  
370 W



- Coolant tray
- Flexible light
- Streamlined double shield motor low surface temperature
- 冷却水槽
- 可灵活转动的工作灯
- 低表面温度的流线型双层马达壳

HBGL650A

150 mm  
370 W



- Coolant tray
- Flexible light
- Quick wheel guard release system
- Streamlined double shield motor low surface temperature
- 冷却水槽
- 可灵活转动的工作灯
- 砂带快速拆卸及调整
- 低表面温度的流线型双层马达壳



TLGS825



200 mm  
500 W



Flexible Work Light  
可灵活转动的工作灯

A flexible work light illuminates the work space, promoting accurate sharpening.  
照明工作区域, 更精确打磨

- Strong cast iron base
- Two sanding position(horizontal&vertical)
- Coolant tray for cooling heated material
- Flexible light (LED available)
- Quick belt release and easy tracking

- 强壮的铸铁底座
- 砂带可水平或垂直设置
- 冷却水槽
- 可灵活转动的工作灯(可选LED灯)
- 砂带快速拆卸及调节

## Technical Data 技术参数

Model/型号	WATT		Ømm		mm x mm		RPM	a x b x h mm	KG	Container load / 装柜数					
	Power/功率 Watts (S1)	Watts (S2 30min)	Dry wheel size/砂轮尺寸 MM Inch	grit / 粒度	Belt size/砂带尺寸 MM Inch	grit / 粒度					Motor speed / 马达转速 50Hz 60Hz	Carton size / 包装尺寸 MM	NW/GW 净重/毛重 KG	20 GP 40 GP 40 HP	
HBGL650A	250	370	150*20*12.7	6*3/4*1/2	36#	50*686	2*27	80#	2980	3580	445*395*245	9.8 / 10.5	675	1305	1450
RBGS625	250	370	150*20*12.7	6*3/4*1/2	36#	50*686	2*27	80#	2980	3580	460*415*265	10.8 / 11.5	560	1120	1400
TDS-150CSL	250	370	150*20*12.7	6*3/4*1/2	60#	50*686	2*27	80#	2980	3580	445*405*265	10.3 / 11.0	560	1160	1450
TLGS625	250	370	150*20*12.7	6*3/4*1/2	60#	50*710	2*28	80#	2980	3580	450*410*295	12.6 / 13.3	560	1120	1260
TLGS825	370	500	200*20*15.88	8*3/4*5/8	60#	50*710	2*28	80#	2980	3580	450*385*345	16.3 / 17.5	450	900	1092
CH820S	550W		200*25*15.88	8*1*5/8	60#	50*1219	2*48	80#	3450		735*580*370	34 / 37	192	390	455

# BENCH GRINDER SANDER

# 砂轮砂带机系列

CH820S

200 mm  
550 W



- Cast iron base and belt frame
- 铸铁底座和砂带床身

## SANDER 砂带机

CH25BS 250 W  
CH50BS 550 W  
CH100BS 550 W



- Solid powerful belt Grinder
- Work stop tilts in to 45°
- Full belt guard with dust collection port
- Belt is adjustable for use in vertical or horizontal position
- 坚固大功率砂带机
- 工作台0到45度可调
- 带排尘口的砂带护罩
- 砂带在0度或90度打磨

## Technical Data 技术参数

Model/型号	WATT		mm x mm		RPM	Linear speed / 砂带线速度 SFFM	a x b x h mm		KG	Container load / 装柜数
	Power/功率 Watts	Watts	Belt size/砂带尺寸 MM Inch	grit / 粒度			MM	NW/GW 净重/毛重 KG		
CH25BS	250		25*1006	1*42	80#	1725	1800	695X465X345	21.5 / 24	246 510 595
CH50BS	550		50*1219	2*48	80#	3450	4500	695X465X345	27.5 / 30	216 510 595
CH100BS	550		100*914	4*36	80#	3450	3600	695X505X345	27 / 29	216 444 518

**TDS-75BR**



75 mm

50 W



**Great Tool For Hobby Use**

- Silence and maintain free less induction motor
- Grinding wheel&wool wheel
- Multi function flexible shaft available
- Rotray shaft and kits box available
- 安静，免维护的感应马达
- 配砂轮和羊毛轮
- 可安装多功能软轴
- 可选配软轴附件包



**Technical Data/技术参数**

Model/型号	WATT		mm	RPM	a x b x h mm	NW / GW 净重/毛重	Container load/装柜数				
	Power/功率						Buffing wheel size/布轮尺寸		Carton size/包装尺寸		
	Watts (S1)	Watts (S2 30min)					MM	Inch	MM	KG	20 GP
TDS-75B	35	50	75*13*10	3*1/2*3/8	2980	3580	290*200*185(inner)	2.0 / 2.2	2844	5580	6664
			75*17*10 (wood)	3*5/8*3/8 (wool)			610*600*200(outer)	12.0 / 14.5	297	627	741
TLG-150BGAC	180	250	150*8*12.7	6*5/16*1/2	2980	3580	505*225*255	9.0 / 9.5	1062	2097	2380
TLG-200BGAC	250	370	200*10*15.88	8*3/8*5/8	2980	3580	545*225*255	15.0 / 16.5	990	1944	2210
TLG-150BGE	180	300	150*8*12.7	6*5/16*1/2	1490	1790	505*225*255	9.0 / 9.5	1062	2097	2380
TLG-200BGE	180	300	200*10*15.88	8*3/8*5/8	1490	1790	545*225*255	15.0 / 16.5	990	1944	2210

**TLG-150BGA / TLG-200BGA**



150 mm 200 mm

**TLG-150BGB / TLG-200BGB**



**TLG-150BGC  
TLG-200BGC**

- 18Inch long shaft distance
- Heavy duty cast iron base for reducing vibration
- Powerful induction motor for reliable performance
- Two buffing wheels, including spiral sewn buffing wheel and Soft buffing wheel
- 457mm长轴距
- 重型铸铁底座可减少机器震动
- 大功率感应马达
- 两个抛光轮，包括一个多线布轮和一个软布轮



**TLG-150BGE / Low Speed Model  
TLG-200BGE / Low Speed Model**

**TDS-250BG / Single Speed  
TDS-250BGH / Two Speed**

150 mm 300 W  
200 mm 300 W



250 mm 750 W  
250 mm 550 W / 750 W



- Powerful induction motor / 大功率感应马达
- Long shaft design / 加长工作轴
- Include spiral sewn buffing wheel and Soft buffing wheel
- 带一个多线布轮和一个软布轮



- Powerful induction motor / 大功率感应马达
- Long shaft design / 加长工作轴
- Two speed for multi application
- 双速设计满足不同需求 ( TDS-250BGH )

**Technical Data/技术参数**

Model/型号	WATT		mm	RPM	a x b x h mm	NW / GW 净重/毛重	Container load/装柜数				
	Power/功率						Buffing wheel size/布轮尺寸		Carton size/包装尺寸		
	Watts (S1)	Watts (S2 30min)					MM	Inch	MM	KG	20 GP
TLG-150BGB	250	370	150*8*12.7	6*5/16*1/2	2980	3580	505*225*255	9.0 / 9.5	1062	2097	2380
TLG-200BGB	370	550	200*10*15.88	8*3/8*5/8	2980	3580	545*225*255	15.0 / 16.5	990	1944	2210
TDS-250BG	550	750	250*20*20	10*3/4*3/4	2980	3580	730*325*265	23.0 / 24.5	448	896	1120
TDS-250BGH	550/750	N/A	250*20*20	10*3/4*3/4	1490/2850	1790/3580	730*325*265	23.0 / 24.5	448	896	1120